

Bussmann®

Productivity Through Protection™

Update on 2005 Code Changes



Table Of Contents

Important Changes to the 2005 Code	Page
Marking Short-Circuit Current Ratings Required	3
440.4(B) Air Conditioning and Refrigeration Equipment	
409.110 Industrial Control Panels	
670.3(A) Industrial Machinery Electrical Panels	
230.82(3) Meter Disconnect Switches on Supply Side of Service Disconnect	
430.8 Motor Controllers	
Selective Coordination of Overcurrent Devices Required	5
100 New Definition for Coordination.	
700.27 Emergency Systems	
701.18 Legally Required Standby Systems	
517.26 Essential Electrical Systems in Health Care Facilities	
240.86(A) Series Ratings in Existing Facilities	9
100 Definition of Supplementary Overcurrent Protective Devices.....	11
240.5(B) Protection of Flexible Cords, Flexible Cables, and Fixture Wires.....	12
240.60(D) Renewable Fuses.....	13
410.73(G) Disconnecting Means for Electric-Discharge Lighting Systems.....	13
430.52(C)(6) Self-Protected Combination Controller.....	14
430.83(E) Voltage Rating for Motor Controllers.....	16
Elevator Circuit Requirements (Did not change for 2005).....	17
620.51(B) Shunt-Trip Elevator Disconnect	
620.62 Selective Coordination Elevator Circuits	
620.91(C) Removal of All Sources of Power on Load Side of Elevator Disconnecting Means	

National Electrical Code® and N.E.C.® are registered trademarks of the National Fire Protection Association (NFPA), Inc., Quincy, MA 02269. This bulletin does not reflect the official position of the NFPA.

Great care has been taken to assure the recommendations herein are in accordance with the N.E.C.® and sound engineering principles. Bussmann® cannot take responsibility for errors or omissions that may exist. The responsibility for compliance with the regulatory standards lies with the end user.

Marking Short-Circuit Current Ratings Now Required

Equipment Protected by Current Limiting Fuses Can Achieve High Short-Circuit Current Ratings

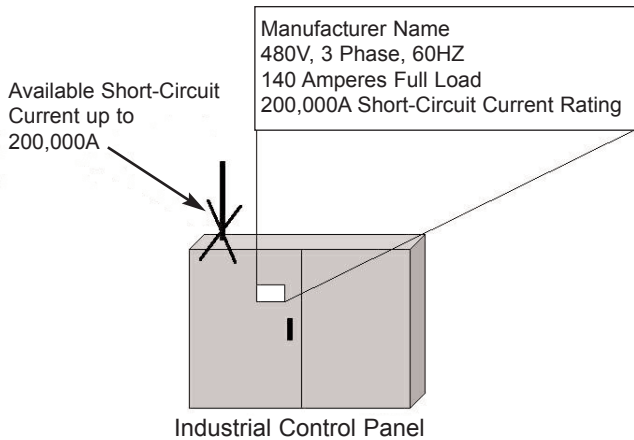

Background

The 2005 NEC® has new requirements for certain equipment and motor controllers to be marked with their short-circuit current rating. This facilitates the inspection and approval process. Inspectors need this information to ensure that 110.10 is met. The potential hazard exists where higher fault currents are available.

It is now required that industrial control panels, industrial machinery electrical panels, certain HVAC equipment, motor controllers and certain meter disconnects be marked with their short-circuit current rating. The next page provides the new NEC® sections. There are exceptions.

Short-circuit current ratings marked on components and equipment make it easier to verify proper protection for components and equipment for specific applications whether it be the initial installation or relocation of equipment. For proper protection and compliance with NEC® 110.10, the short-circuit current rating for a component or equipment shall be equal to or greater than the available short-circuit current where the equipment is being installed in the system.

Ensuring Compliance

For the affected types of equipment, simply require the following:

1. For the plan review process, the engineer supplies the available short-circuit current at each equipment installation point and the specific short-circuit current rating for each piece of equipment or industrial control panel.

2. Upon site inspection, compare the actual equipment marked short-circuit current rating to the submitted data to ensure the rating is indeed as specified and sufficient for the available short-circuit current available at the point of installation.

Another simpler method if all the equipment has high short-circuit current ratings:

1. Verify the maximum, worst case short-circuit current available at the terminals of the supply transformer.
2. If all the equipment in the system has short-circuit current ratings greater than this maximum, worst case available short-circuit current, then the detailed short-circuit current study is not necessary. Equipment properly protected by current-limiting fuses can easily achieve short-circuit current ratings of 100,000A or 200,000A.

New Requirements

Air Conditioning and Refrigeration Equipment with Multimotor and Combination-Loads

440.4(B) requires the nameplate of this equipment to be marked with its short-circuit current rating. There are exceptions for which this requirement does not apply to this equipment:

- one and two family dwellings,
- cord and attachment-plug connected equipment,
- or equipment on a 60A or less branch circuit.

So for most commercial and industrial applications, air conditioning and refrigeration equipment with multimotor and combination loads must have the short-circuit current rating marked on the nameplate.

Industrial Control Panels

Article 409 Industrial Control Panels is a new article as of the 2005 NEC®. 409.110 requires that an industrial control panel be marked with its short-circuit current rating.

Industrial Machinery Electrical Panel

670.3(A) requires the industrial control panel nameplate of industrial machinery to include its short-circuit current rating. In the past, the NEC® required that the machine nameplate include only the interrupting rating of the machine overcurrent protective device, if one was furnished. This marking could be misleading as it did not

represent the short-circuit current rating of the entire machine, but could be mis-interpreted as such.

Meter Disconnect Switches (rated up to 600V)

230.82(3) permits a meter disconnect switch ahead of the service disconnecting means, provided the meter disconnect switch has a short-circuit current rating adequate for the available short-circuit current.

Motor Controllers

Component Marking – **430.8** now requires that motor controllers be marked with their short-circuit current rating. There are some exceptions.

A motor controller illustrates this point very well. The Bussmann® compact, non-fused disconnect, the CDN63, is a Listed UL 508 Manual Motor Controller with a maximum horsepower rating of 40hp at 480V. It is marked with a short-circuit current rating of 5kA when protected by up to a 150A Class H fuse. However, the short-circuit current rating for the CDN63 is marked 100kA when protected with up to a Bussmann® LPJ-100SP fuse (100A Class J) or JJS-100 fuse (100A Class T).

What is Short-Circuit Current Rating?

“Short-circuit current rating” is **not** the same as interrupting rating and the two must not be confused.

Interrupting rating is the maximum short-circuit current a fuse or circuit breaker can safely interrupt under standard test conditions; it does not ensure protection of the circuit components or equipment. Adequate interrupting rating is required per NEC® 110.9

Short-circuit current rating is the maximum short-circuit current a component or equipment can safely withstand when protected by a specific overcurrent protective device or for a specified time. Adequate short-circuit current rating is required per NEC® 110.10.

Easiest Way To Achieve High Short-Circuit Current Ratings

Equipment and controllers with higher short-circuit current ratings will be more attractive and easier to specify, install, and meet compliance. Plus when equipment is moved to another location, as is often done with industrial machinery, high short-circuit current ratings ensure safer installations. Protection with current limiting fuses is the easiest and most effective way to achieve higher short-circuit current ratings.

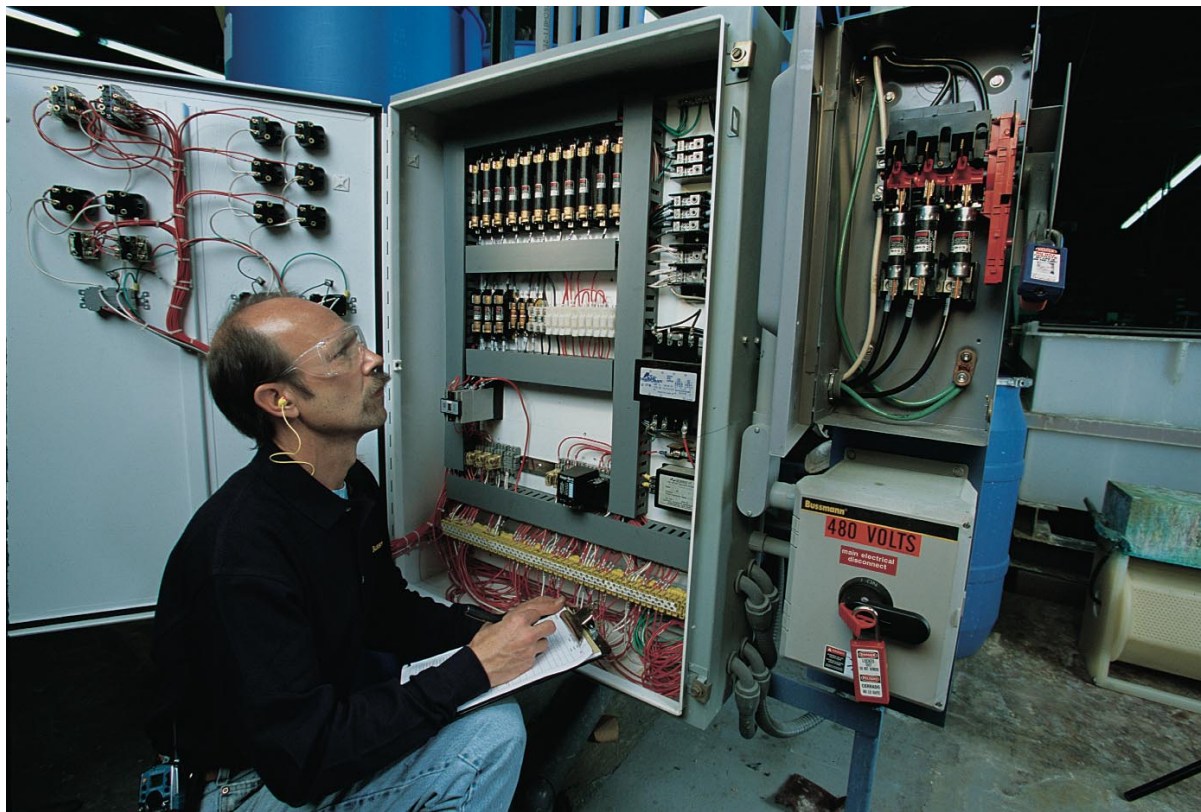

Selective Coordination Now Required For Emergency Systems, Legally Required Standby Systems, and Essential Electrical Systems in Health Care Facilities

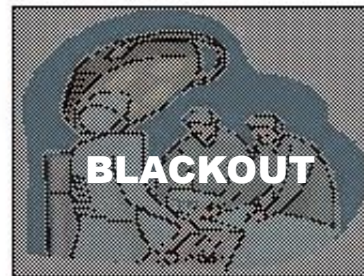

Background

Selective coordination is now required for increased system reliability, which is vital for these critical systems. **Selective coordination** can be defined as isolating an overloaded or faulted circuit from the remainder of the electrical system by having **only** the nearest upstream overcurrent protective device open. The following was added to NEC® 2005

Article 100 Definitions: Coordination (Selective).
Localization of an overcurrent condition to restrict outages to the circuit or equipment affected, accomplished by the choice of overcurrent protective devices and their ratings or settings.

The one-line diagrams in Figure 1 and Figure 2 demonstrate the concept of selective coordination.

Selective coordination is an important new NEC® 2005 requirement that is consistent with the critical need to keep these loads powered even with the loss of normal power. **Article 700, Emergency Systems, and Article 701, Legally Required Standby Systems** have several requirements that are based upon providing a system with reliable operation, reduction in the probability of faults and minimizing the effects of an outage to the smallest portion of the system as possible. **Article 517, Health Care Facilities,** requires **essential electrical systems** to meet the requirements of Article 700 except as amended in Article 517. The objective of these requirements is to ensure system uptime with the goal of safety of human life during emergencies or for essential health care functions. Selective

coordination of overcurrent devices fits well with the other requirements such as:

- **700.4** maintenance and testing requirements
- **700.9(B)** emergency circuits separated from normal supply circuits
- **700.9(C)** wiring specifically located to minimize system hazards
- **700.16** failure of one component must not result in a condition where a means of egress will be in total darkness

Ensuring Compliance

Achieving the proper overcurrent protective device selective coordination requires proper engineering, specification and installation of the required devices.

During the plan review process, it is the design engineer's responsibility to provide documentation that verifies the overcurrent devices are selectively coordinated for the full range of overcurrents that can occur in the system. And the site inspection should verify the overcurrent protective devices are installed as specified to achieve selective coordination.

It is possible for both fusible and circuit breaker systems to be selectively coordinated with proper analysis and selection. Selective coordination is easy with Bussmann® fuses by using the published fuse selective coordination ratios; a full short-circuit and coordination study is not necessary to verify selective coordination. Selective coordination with circuit breakers depends on their characteristics and settings as well as the circuit parameters for the specific application. It

is generally difficult to achieve selective coordination with common circuit breakers that incorporate instantaneous trip settings. Typically circuit breakers with short-time delay settings or zone selective interlock features may be necessary, which can add to the cost and may create other system issues. If using **zone selective interlocking options**, molded case and insulated case circuit breakers **still have an instantaneous trip that overrides the zone selective tripping feature**. This is necessary to protect the circuit breaker from severe damage. Consequently blackouts can occur even with this zone selective interlocking feature. If circuit breakers are to be considered, a full short-circuit current and coordination study must be done with proper analysis and interpretation. See simple fuse and circuit breaker examples are on page 8.

Example (See Figures 1 & 2)

If overcurrent protective devices in the emergency system are not selectively coordinated, a fault at X₁ on the branch circuit may unnecessarily open the sub-feeder; or even worse the feeder or possibly even the main. In this case, emergency circuits are unnecessarily blacked out. With selective coordination as a requirement for emergency, legally required standby, and essential electrical systems, when a fault occurs at X₁ only the nearest upstream fuse or circuit breaker supplying just that circuit would open. Other emergency loads would remain powered.

New Requirements

2005 NEC®

700.27 Coordination. *Emergency system(s) overcurrent devices shall be selectively coordinated with all supply side overcurrent protective devices.*

701.18. Coordination. *Legally required standby system(s) overcurrent devices shall be selectively coordinated with all supply side overcurrent protective devices.*

517.26 Application of Other Articles. *The essential electrical system shall meet the requirements of Article 700, except as amended by Article 517.*

Notes:

1. Article 517 has no amendment to the selective coordination requirement, therefore selective coordination is required.
2. Selective coordination is required for both the normal supply path and the emergency system path.

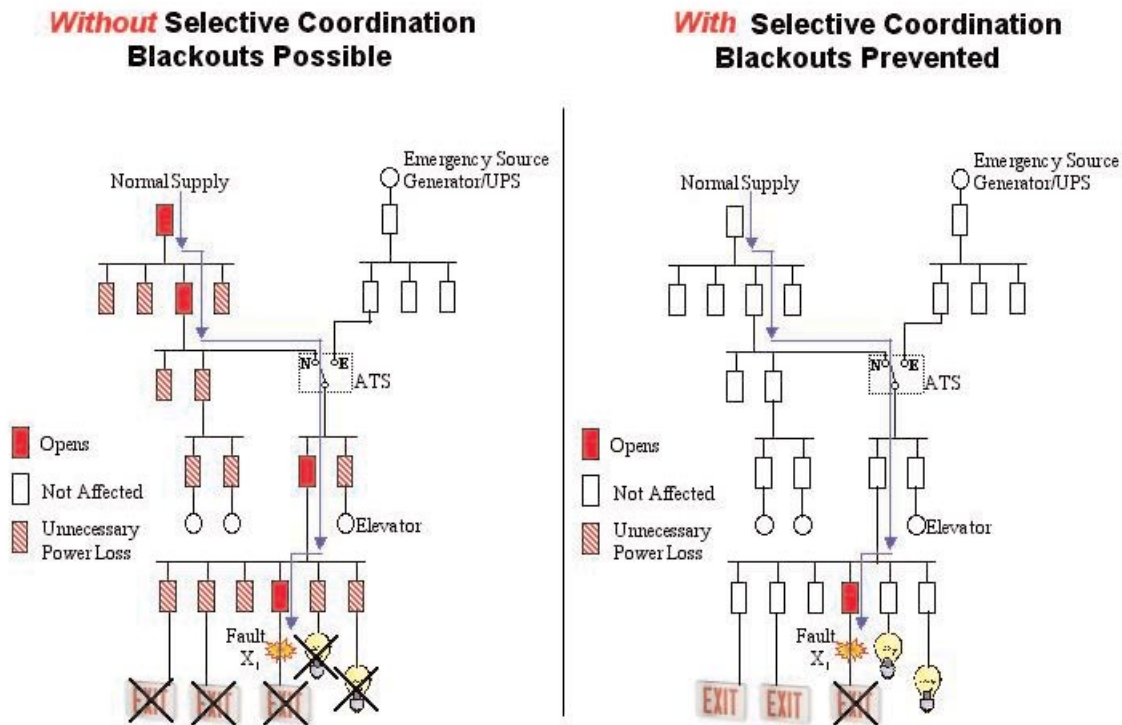
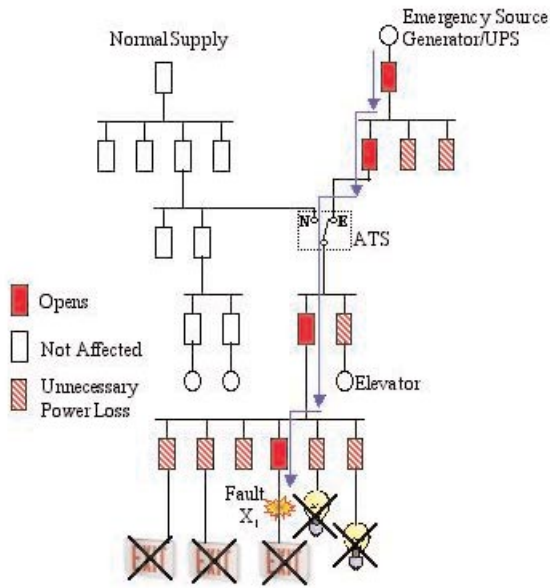

Figure 1 - Normal Source Power to Emergency Circuits

Without Selective Coordination Blackouts Possible



With Selective Coordination Blackouts Prevented

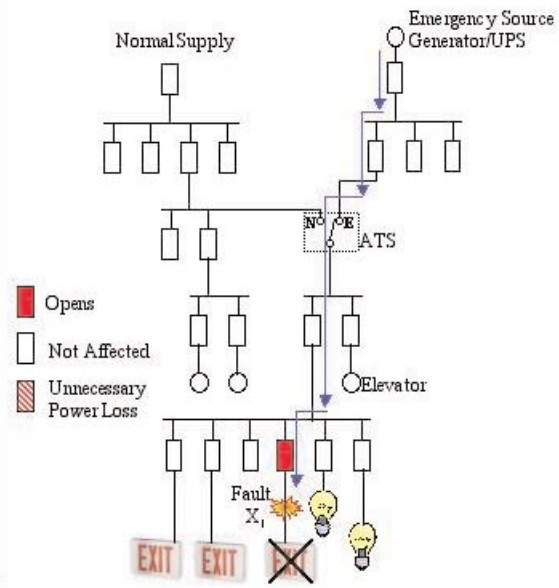
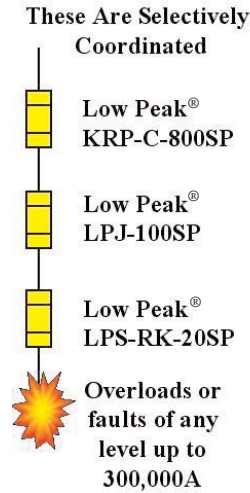

Figure 2 - Emergency Service Power to Emergency Circuits

The Cooper Bussmann **SPD Selecting Protective Devices** publication (download from www.bussmann.com) has an in-depth discussion on selective coordination analysis with the published fuse selectivity ratios, some simple

evaluation rules for coordination of instantaneous trip circuit breakers, and illustration of short-time delay circuit breakers. Go to www.bussmann.com for Bussmann® Fuse Selectivity Ratios Interactive Guide under Application Info/Software.



		Loadside Fuse		
		KRP-C_SP	LPJ_SP	LPS-RK_SP
Lineside Fuse	KRP-C_SP	2:1	2:1	2:1
	LPJ_SP	-	2:1	2:1
	LPS-RK_SP	-	2:1	2:1

Lineside KRP-C-800SP to Loadside LPJ-100SP
800/100=8:1 Table shows only 2:1 needed
Therefore Selective Coordination achieved

Lineside LPJ-1000SP to Loadside LPS-RK-20SP
100/20=5:1 Table shows only 2:1 needed
Therefore Selective Coordination achieved

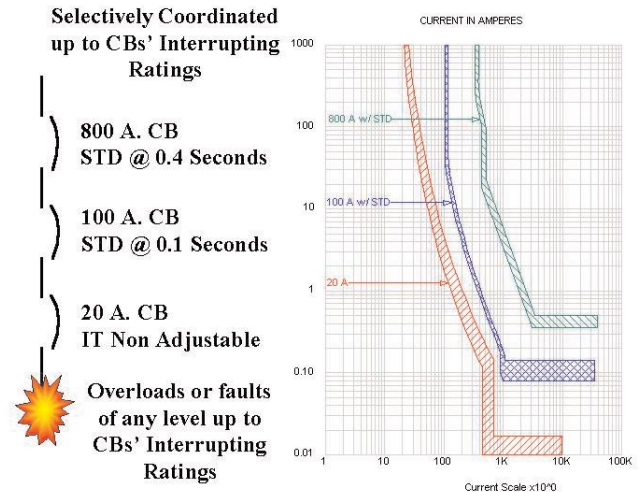
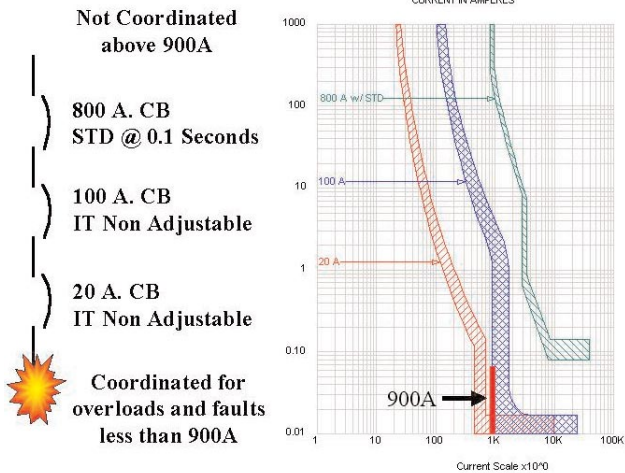

1. If circuit breakers are not maintained, extended clearing times or nuisance operation may compromise coordination.
2. If using zone selective interlocking option, molded case and insulated case circuit breakers still have an instantaneous trip that overrides the zone selective tripping feature. Blackouts still can occur since selective coordination can not be achieved.

Other Information

Emergency systems are considered in places of assembly where artificial illumination is required and for areas where panic control is needed such as hotels, theaters, sports arenas, health care facilities, and similar institutions. Emergency systems also provide power to functions for ventilation, fire detection and alarm systems, elevators, fire pumps, public safety communications, or industrial processes where interruption could cause severe human safety hazards.

Legally required standby systems are intended to supply power to selected loads in the event of failure of the

normal source. Legally required standby systems typically serve loads in heating and refrigeration, communication systems, ventilation and smoke removal systems, sewage disposal, lighting systems, and industrial processes where interruption could cause severe human safety hazards.

Essential electrical systems in healthcare facilities are portions of the electrical system designed to ensure continuity of lighting and power to designated areas/functions during normal source power disruptions or disruptions within the internal wiring system. Essential electrical systems can include the critical branch, life safety branch, and equipment systems which are essential for life safety and orderly cessation of procedures during normal power disruptions.

240.86(A) Series Ratings in Existing Facilities

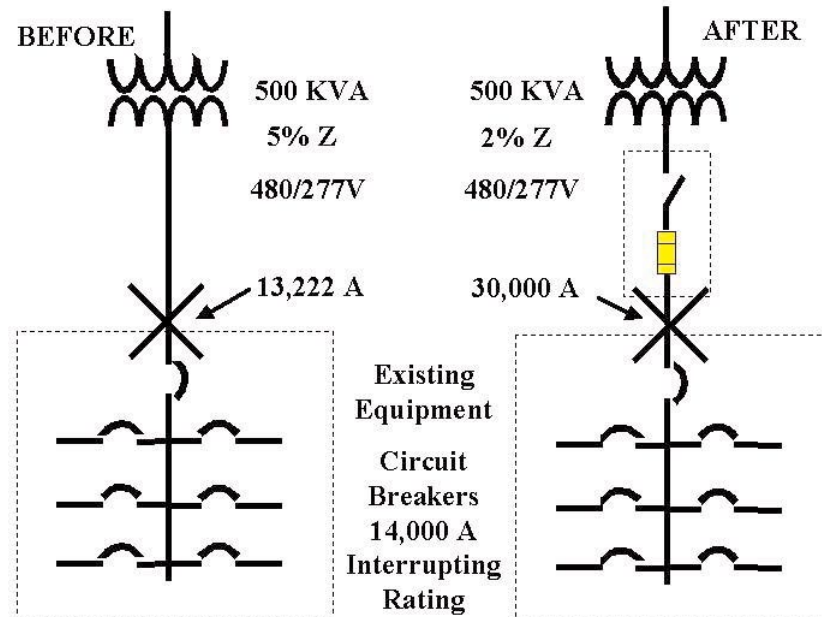

Background

The new **240.86(A)** permits selection of series ratings for existing systems when the selection is made by a licensed professional engineer. When buildings undergo improvements or if new transformers are installed, quite often the new available short-circuit-current exceeds the existing circuit breakers' interrupting rating. This is a serious safety hazard and does not comply with NEC® 110.9. Prior to the 2005 NEC®, under this condition, about the only option an owner had was to remove and scrap the existing circuit breaker panel and install a new circuit breaker or fusible switch panel that has overcurrent protective devices that are sufficient for the new available short-circuit current. This is very expensive and disruptive.

Now for existing systems, a licensed professional engineer can determine if an upgrade of lineside fuses or circuit breakers can series rate with existing loadside circuit breakers. This new option may save an owner significant

money and provide a safer system than if no action is taken when the available short-circuit current exceeds the installed circuit breakers' interrupting rating.

For new installations, the process remains the same as the 2002 NEC®: the series rated combinations shall be tested, listed and marked for use with specific panel boards and switchboards.

Ensuring Compliance

Require the engineer to provide the necessary analysis that insertion of a set of lineside fuses or circuit breaker can provide protection to the downstream circuit breakers. The documentation for the selection of series ratings for existing systems shall be stamped by the engineer and be readily available to those involved in the design, installation, inspection, maintenance and operation of the equipment installation.

New Requirement

2005 NEC®

240.86 Series Ratings. *Where a circuit breaker is used on a circuit having an available fault current higher than the marked interrupting rating by being connected on the load side of an acceptable overcurrent protective device having a higher rating, the circuit breaker shall meet the requirements specified in (A) or (B), and (C).*

(A) Selected Under Engineering Supervision in Existing Installations. *The series rated combination devices shall be selected by a licensed professional engineer engaged primarily in the design or maintenance of electrical installations. The selection shall be documented and stamped by the professional engineer. This documentation shall be available to those authorized to design, install, inspect, maintain, and operate the system. This series combination rating, including identification of the upstream device, shall be field marked on the end use equipment.*

(B) Tested Combinations. *The combination of line-side overcurrent device and load-side circuit breaker(s) is tested and marked on the end use equipment, such as switchboards and panelboards.*

(C) Motor Contribution. *Series ratings shall not be used where*

- (1) *Motors are connected on the load side of the higher rated overcurrent device and on the line side of the lower-rated overcurrent device, and*
- (2) *The sum of the motor full-load currents exceeds 1 percent of the interrupt rating of the lower-rated circuit breaker.*

Methods To Series Rate Existing Systems

There may be several analysis options for a licensed professional engineer to rectify the situations where existing circuit breakers have inadequate interrupting ratings. In some cases, a suitable method may not be feasible. New methods may surface in the future.

Some methods:

1. Check to see if a new fused disconnect can be installed ahead of the existing circuit breakers by using a listed series rated combination. Even though the existing system may not take advantage of series ratings, if the existing circuit breakers are not too old, the panel may have a table or booklet that provides all the possible listed combinations of fuse-circuit breaker series ratings.

2. If the existing system used series ratings with Class R fuses, analyze whether a specific Bussmann® Class RK1, J or T fuse may provide the protection at the higher short-circuit current. The series ratings for panelboards that use lineside Class R fuses have been determined with special, commercially unavailable Class RK5 umbrella fuses (Commercially unavailable umbrella fuses are only sold to electrical equipment manufacturers in order to perform equipment short-circuit testing) Actual, commercially available Bussmann® Class RK1, J or T fuses will have current-limiting let-through characteristics considerably less than the Class RK5 umbrella limits.
3. Supervise short circuit testing of lineside current-limiting fuses to verify that protection is provided to circuit breakers that are identical to the installed, existing circuit breakers.
4. Perform an analysis to determine if a set of current-limiting fuses installed on the lineside of the existing circuit breakers provides adequate protection for the circuit breakers. For instance, if the existing equipment is low voltage power circuit breakers (approximately three cycle opening time), then the line-side fuse short-circuit let-through current (up, over, and down method) must be less than the circuit breaker's interrupting rating. An appropriate analysis method has yet to be found for circuit breakers that clear in less than a 1/2 cycle. It is possible, but a practical analysis method based on present available circuit breaker data is not yet feasible

Suggestion for New Installations

Use Bussmann® Low-Peak® Fuses throughout system for a fully rated system:

1. The owner does not have to unexpectedly make significant changes to the electrical system because the short-circuit current increased after the initial installation. KRP-C_SP, LPJ_SP, LPN-RK_SP, and LPS-RK_SP Low-Peak® fuses have interrupting ratings of 300,000A. This is adequate for all but a few installations in the world.
2. The owner does not have to have required periodic maintenance and testing performed on fuses to ensure their ability to operate as intended.

Note

A new “**240.93 Series Ratings,**” is shown in the first printing of the 2005 NEC®. **It appears that this is a misprint and will be removed** from future editions. The requirements of 240.86 apply to Part VIII. Supervised Industrial Installations. There are no special requirements or allowances in 240.93 for series ratings for Supervised Industrial Installations.

100 Definition: Supplementary Overcurrent Protective Device

A definition for Supplementary overcurrent protective device has been added to Article 100. This definition has been added to help avoid serious misapplication of devices that have not been tested for general purpose usage. Supplementary overcurrent protective devices must not be applied where branch circuit overcurrent protective devices are required; unfortunately this unsafe misapplication is prevalent in the industry.

New Definition

2005 NEC®

Supplementary Overcurrent Protective Device. A device intended to provide limited overcurrent protection for specific applications and utilization equipment such as luminaires (lighting fixtures) and appliances. This limited protection is in addition to the protection provided in the required branch circuit by the branch circuit overcurrent protective device.

Supplementary overcurrent protective devices are not general use devices, as are branch circuit devices, and must be evaluated for appropriate application in every instance where they are used. Supplementary overcurrent protective devices are extremely application oriented and prior to applying the devices, the differences and limitations for these devices must be investigated and found acceptable.

Examples of supplemental overcurrent protective devices include, but are not limited to the following:



UL248-14
Supplemental Fuses



UL1077 Supplemental
Protectors (Mini Circuit Breakers)

One example of the difference and limitations is that a supplementary overcurrent protective device may have spacings, creepage and clearance, that are considerably less than that of a branch circuit overcurrent protective device.

Example:

- A supplemental protector, UL1077, has spacings that are 3/8 inch through air and 1/2 inch over surface at 480V.
- A branch circuit rated UL489 molded case circuit breaker has spacings that are 1 inch through air and 2 inches over surface at 480V.

Another example of differences and limitations is that branch circuit overcurrent protective devices have standard overload characteristics to protect branch circuit and feeder conductors. Supplementary overcurrent protective devices do not have standard overload characteristics and may differ from the standard branch circuit overload characteristics. Also, supplementary overcurrent protective devices have interrupting ratings that can range from 32 amps to 100,000 amps. When supplementary overcurrent protective devices are considered for proper use, it is important to be sure that the device's interrupting rating equals or exceeds the available short-circuit current and that the device has the proper voltage rating for the installation (including compliance with slash voltage rating requirements, if applicable).

Reasons Why Supplemental Protectors (UL1077 Devices) can not be used to Provide Branch Circuit Protection

1. Supplemental Protectors are not intended to be used or evaluated for branch circuit protection in UL1077
2. Supplemental protectors have drastically reduced spacings, compared to branch circuit protective devices, which depend upon the aid of a separate branch circuit protective device upstream
3. Supplemental protectors do not have standard calibration limits or overload characteristics performance levels and cannot assure proper protection of branch circuits
4. Multipole supplemental protectors for use in 3 phase systems are not evaluated for protection against all types of overcurrents
5. Most supplemental protectors are tested with a branch circuit overcurrent device ahead of them and rely upon this device for proper performance
6. Supplemental protectors are not required to be tested for closing into a fault
7. Recalibration of a supplemental protector is not required and depends upon manufacturer's preference. There is no assurance of performance following a fault or resettability of the device.
8. Considerable damage to a supplemental protector is allowed following short circuit testing.
9. Supplemental protectors are not intended to:
 - Provide Branch Circuit Protection
 - Be used as a Disconnecting Means
10. Supplemental protectors are not evaluated for short circuit performance criteria, such as energy let through limits or protection of test circuit conductors

For a more in depth discussion see TECH TALK 3 found on www.bussmann.com.

240.5(B) Protection of Flexible Cords, Flexible Cables, and Fixture Wires

Prior to the 2005 NEC® the supply cords of listed appliances, portable lamps, and listed extension cord sets were “assumed” to be protected by the branch circuit overcurrent protective device. There has been a change to the 2005 NEC® that removes this assumption. The new requirement considers these cords to be protected when applied within the listing requirements.

There has been a lot of focus on preventing fires due to arcing faults in recent code cycles. This focus has brought about the requirements for AFCI protection on bedroom circuits. Many of the studies that were used to substantiate the AFCI requirement show that as many as 60% of all electrical fires started on the load side of the outlet. The fires start in the extension cords, supply cords, and appliances. This new requirement places the responsibility on the cord/equipment manufacturers and product safety standards to evaluate the protection of the appliances and cords, and any possible necessity for supplemental overcurrent protection.

Nationally Recognized Testing Laboratories (NRTLs) and the equipment manufacturers will now have to determine if the small wire is properly protected. Some equipment that has never caused fires will not be affected. But other equipment that has a poor record for causing fires will likely be required to provide the protection of their cords. That protection might come in the form of supplementary fuses, AFCIs, GFCIs, or a combination of two or more of these.

Fused line cords are one of the possible and least costly solutions for equipment that may cause a fire. This is currently a common practice for holiday lights. This method is also widely used in the UK and Japan.

In addition Cooper Bussmann provides a specialty fuse targeted specifically for electric cord applications. The ECF fuse (electric cord fuse) is an integral fuse and cord-plug blade. The cord-plug blade is stamped “fuse” and is non-polarized (“hot”). The fuse ampere rating is stamped on the fuse ferrule. Appliance manufacturers and plug/cord manufacturers can incorporate the ECF fuse into their plug design. This is a simple, reliable, low cost means to protect cords and appliances.

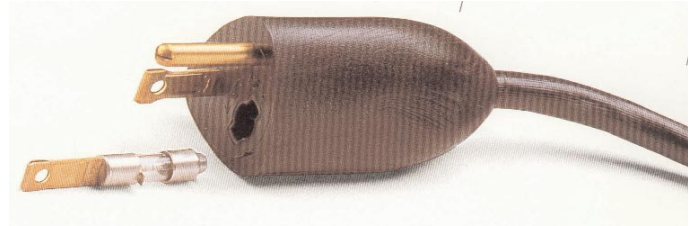

The presently available ampere ratings range from 1/2A to 5A. For high volume applications requiring amperage ratings outside this range, please contact Cooper Bussmann sales or representatives.

Some of the features of this concept:

- Dual protection: can protect the power cord and appliance against overcurrents
- Superior fault protection: ECF fuses can be sized properly and are fast acting on short-circuits
- No-space protection: no additional space is needed to get the necessary protection
- Supplementary fusing feasible: this makes it practical to provide line cord fusing
- Cost effective: no additional fuseholder or blocks within the housing of the product
- Easy replacement: push, twist, and pull out and then the reverse action to install. Can be designed so that the ECF fuse securely locks in with a positive-hold spring lock
- Fuse replacement is shock proof: the cord plug must be removed from the outlet receptacle to replace the ECF fuse
- Size rejecting: ECF fuses are designed to be size rejecting for various ampere rating ranges. Therefore, ECF fuses greater than the specific ampere rating range are rejected

Blade-Fuse Part No.	Fuse Rating	Maximum Ampere Rating Physical Restriction
ECF-1/2	1/2A	2A
ECF-1	1A	
ECF-11/2	11/2A	
ECF-2	2A	4A
ECF-3	3A	
ECF-4	4A	6A
ECF-5	5A	

240.60(D) Renewable Fuses

The 2005 NEC® has new requirements that prohibit the use of Class H renewable fuses for new installations. The reasoning given in the original proposal submitted for this restriction was that renewable fuses were posing significant safety issues. The code making panel statement did not support the claims of the safety issues, however, they chose to support the proposal because of the minimal 10,000 amp interrupting rating. Renewable fuses that are applied within their ratings and where there is no evidence of tampering are permitted for replacement in existing installations.

This new requirement supports the use of devices with higher interrupting ratings. New equipment should be installed using Fusetron® (RK5) fuses which have a 200,000A IR, or preferably Low-Peak® (RK1, J, CC or L) fuses which have a 200,000A IR for LP-CC fuses and 300,000A IR for the others. It is also important if Class R fuses are used, then install switches with rejection fuse clips, so that Class H fuses cannot be used for later replacement. Class J, L, T, CC, and G fuses, as well as, the CUBEFuse™ mounting are all physical size rejecting so only that respective Class of fuse can be installed. This ensures the installation maintains its high interrupting rating.

In addition to the highest interrupting ratings of all overcurrent protective devices, modern current-limiting fuses provide:

- The best equipment protection
- The easiest overcurrent protective devices to selectively coordinate
- Reliable overcurrent protection over the life of the system
- No maintenance necessary

- The best reduction of the arc flash hazard when the arcing current is within the current limiting range of the fuse
- Physical size rejecting feature
- Class R fuses can be installed in Class H clips.

New Requirement

2005 NEC®

240.60(D) Renewable Fuses. Class H cartridge fuses of the renewable type shall only be permitted to be used for replacement in existing installations where there is no evidence of overfusing or tampering.



Example of renewable fuses



Low-Peak current-limiting fuses

410.73(G) Disconnecting Means for Electric-Discharge Lighting Systems

The 2005 NEC® has a new article requiring individual disconnecting means for ballasted electric discharge lighting that have double ended lamps, or those that are fed by multiwire branch circuits (with some exceptions). Industry data has shown that a leading cause of fatalities for electricians is electrocution while working on 277V lighting systems. Electricians are often pressured to change out ballasts while the circuits are energized to avoid removing illumination from an area. When the electrician gets to the wire nut with three white wires (neutral), the thought is that these are grounded conductors, and therefore are not

hazardous. The electrician opens the wire nut and gets between two of the white wires, which can result in shock or electrocution. These white wires carry the unbalanced load current from all phases of the white wires.

This new requirement will allow electricians to de-energize a ballasted luminaire without removing illumination to an entire area. Then they can safely change out the ballast without being exposed to a shock hazard. This change has been given an effective date of January 1st, 2008 to allow manufacturers time to develop products for this application.

430.52(C)(6) Self-Protected Combination Controller

Individual Pole-Interrupting Capability

Self-protected combination controllers are intended to provide motor overload, and motor branch circuit short-circuit and ground fault protection. They are essentially the same as circuit breakers when it comes to short-circuit protection. And like circuit breakers, they have limitations on how much short-circuit current a single pole can interrupt (individual pole interrupting capability). Self-protected combination controllers are listed to UL 508 Industrial Control Equipment. UL508 Table 82A.3 specifies the short circuit test values on one pole as 8,660 amps for 0 to 200 hp devices rated up to 600 volts and 4320A for 0 to 10hp devices rated 200 to 250V. Self-protected combination controllers may not be able to safely interrupt single-pole faults above these values. **These devices must not be used in an application where a single pole is subjected to more fault current than specified in UL 508 (8,660A for 0 to 200 hp devices rated up to 600 volts and 4320A for 0 to 10hp devices rated 200 to 250V). This may easily occur on corner grounded delta systems, impedance grounded systems, and ungrounded systems.**

For this reason a FPN was added to the 2005 NEC® that matches the FPN added to 240.85 for the 2002 NEC® for circuit breakers. While the FPN is not a requirement it does alert users that proper application of these devices takes the individual pole interrupting capability into consideration.

New Fine Print Note

2005 NEC®

430.52(C)(6) FPN: Proper application of self-protected combination controllers on 3-phase systems, other than solidly grounded wye, particularly on corner grounded delta systems, considers the self-protected combination controllers' individual pole-interrupting capability.



Individual-Pole Interrupting Ratings

This is a single-pole interrupting test on a circuit breaker to illustrate the concept.

480 Volt, Available 25,000 Amps Line-to-Ground

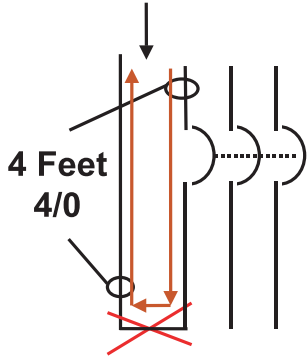

Single-Pole Test of Three-Pole Device

225 Amp Circuit Breaker
Marked 35,000 Amp Interrupting Rating
(Three-Pole Rating Only)

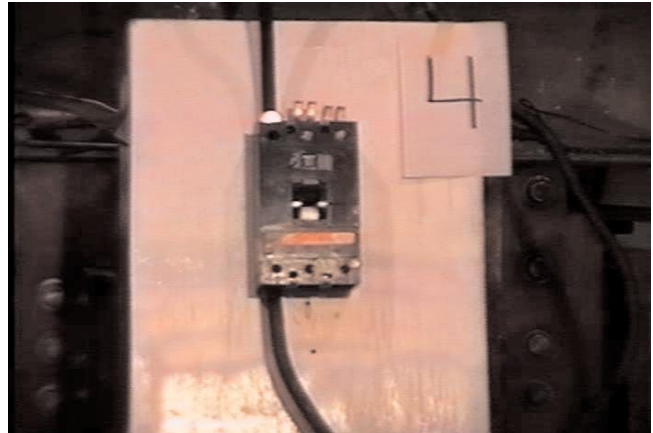

Test set up prior to closure of test station

This device is tested for three-pole interruption with available fault of 35kA and is test for individual single-pole interruption of only 8,660 amps per UL 489

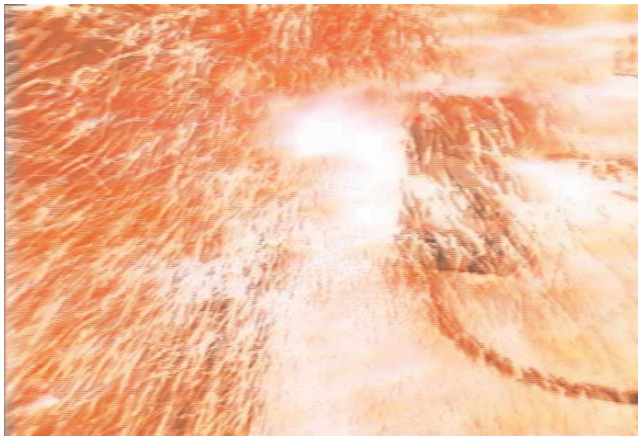

Photo of 3-pole device during test of individual single-pole interruption of a fault current beyond the tested values specified by the UL standard



Photo (later in sequence) of 3-pole device during test of individual single-pole interruption of a fault current beyond the tested values specified by the UL standard

430.83(E) Voltage Rating for Motor Controllers

Slash Voltage Rating

The 2005 NEC® section covering voltage ratings for motor controllers was changed to address the proper application of slash-rated devices. A slash-rated motor controller is one with two voltage ratings separated by a slash, such as 480Y/277 volt. The change was the addition of the words “solidly grounded”. This was needed to emphasize that slash-rated devices are not appropriate for use on corner grounded delta, resistance-grounded and ungrounded systems.

This typically pertains to the self-protected combination controllers mentioned in the previous section. Most of them are “dual listed.” Dual listed controllers will have one listing as a manual motor controller that has a straight 480 volt rating. When used as a manual motor controller they can be used any 480 volt system, but they must be protected by a fuse or circuit-breaker. Dual listed devices also have a second listing as a self-protected motor controller. The self-protected starter listing is nearly exclusively rated 480Y/277. These slash-rated devices cannot be used on corner-grounded delta, resistance grounded, or ungrounded systems.

Where it is possible for full phase-to-phase voltage to appear across only one pole, a slash-rated device is not acceptable. These self-protected starters are typically listed with a straight 480 volt rating when utilized as a manual motor controller. As such, they can be used on other than solidly grounded systems, but only for their on/off function and overload protection.

When slash-rated devices such as self-protected motor controllers are installed in equipment, it limits the application of the equipment to solidly grounded wye systems. The equipment nameplate must also be marked with the slash-rating (e.g. 480Y/277) to clearly indicate that it is limited by the type of grounding system. This limits the entire equipment or panel to solidly grounded systems only.

The advantage of fuses is that they are tested with full voltage across the fuse, and therefore are not limited by the type of grounding systems. Equipment that has slash-rated devices for short-circuit protection can often be retrofitted with fuses (such as LP-CC fuses with the OPM-NG holder) to eliminate the limitations.

2005 NEC®

VII. Motor Controllers

430.83 Ratings.

(E) Voltage Rating. A controller with a straight voltage rating, for example, 240 volts or 480 volts, shall be permitted to be applied in a circuit in which the nominal voltage between any two conductors does not exceed the controller’s voltage rating. A controller with a slash rating, for example, 120/240 volts or 480Y/277 volts, shall only be applied in a solidly grounded circuit in which the nominal voltage to ground from any conductor does not exceed the lower of the two values of the controller’s voltage rating and the nominal voltage between any two conductors does not exceed the higher value of the controller’s voltage rating.

Ensuring Compliance

Solidly Grounded WYE System

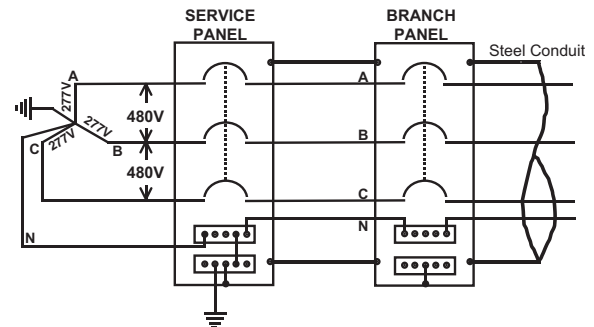

Figure 1 – Solidly Grounded WYE System

Solidly Grounded WYE System

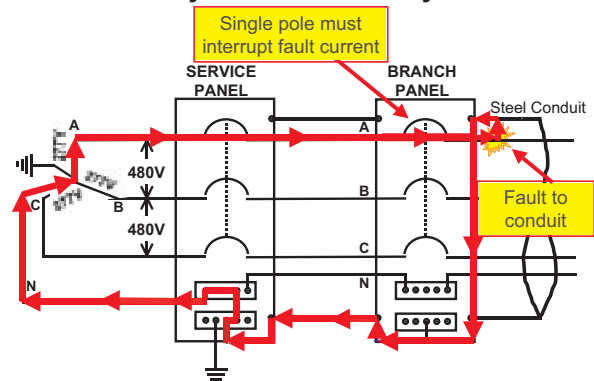

Figure 2 – Single-Pole Fault to Ground in Solidly Grounded WYE System

In solidly grounded wye systems, the first low impedance fault to ground is generally sufficient to open the overcurrent device on the faulted leg. In Figure 2, this fault current causes the branch circuit overcurrent device to clear the 277V fault. This system requires compliance with single-pole interrupting capability for 277V faults on one pole. If the overcurrent devices have a single-pole interrupting capability adequate for the available short-circuit current, then the system meets NEC® 110.9. When other than solidly grounded wye systems are encountered, it is absolutely essential that the proper application of single-pole interrupting capabilities be assured. This is due to the fact that full phase-to-phase voltage can appear across just one pole. Phase-to-phase voltage across one pole is much more difficult for an overcurrent device to clear than the line-to-neutral voltage associated with the solidly grounded wye systems.

Corner Grounded Delta System

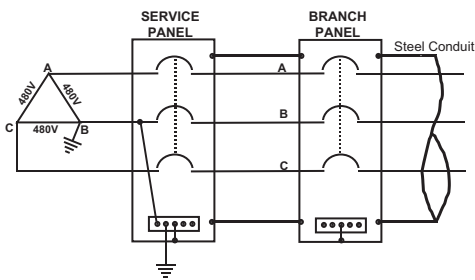

Figure 3 – Corner-Grounded Delta System (Solidly Grounded)

The system of Figure 3 has a delta-connected secondary and is solidly grounded on the B-phase. If the B-phase should short to ground, no fault current will flow because it is already solidly grounded. If either Phase A or C is shorted to ground, only one pole of the branch-circuit overcurrent device will see the 480V fault as shown in Figure 4. This system requires compliance with single-pole interrupting capabilities for 480V faults on one pole because the device would be required to interrupt 480V with only one pole.

For more in depth discussion on single-pole interruption, see publication SPD Selecting Protective Devices that can be found on www.bussmann.com.

Corner Grounded Delta System

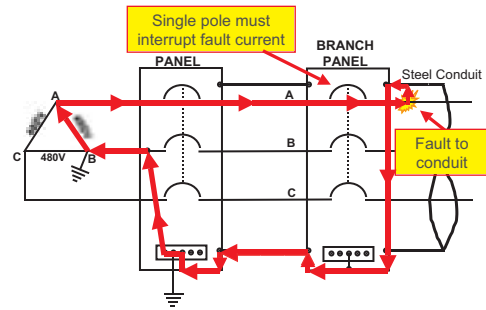
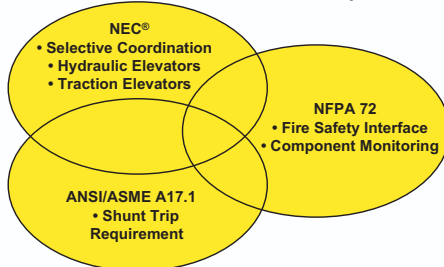

Figure 4 – Fault to Ground on a Corner Grounded Delta System

Elevator Circuit Requirements

The NEC® requirements discussed on the next two pages are not new nor have they changed with the 2005 NEC®. However, elevator circuits are an important application for life safety. In addition, usually there are three disciplines involved in the design, installation, and inspection of elevator systems; this can result in complications and even improper installations.

POWER MODULE™ Elevator Disconnect
All-in-One Solution for Three Disciplines



When sprinklers are installed in elevator hoistways, machine rooms, or machinery spaces, ANSI/ASME A17.1 requires that the power be removed to the affected elevator upon or prior

to the activation of these sprinklers. This is an elevator code requirement that affects the electrical installation. The electrical installation allows this requirement to be implemented at the disconnecting means for the elevator in NEC® **620.51(B)**. This requirement is most commonly accomplished through the use of a shunt trip disconnect and its own control power. To make this situation even more complicated, interface with the fire alarm system along with the monitoring of components required by NFPA 72 must be accomplished in order to activate the shunt trip action when appropriate and as well as making sure that the system is functional during normal operation. This requires the use of interposing relays that must be supplied in an additional enclosure. Other requirements that have to be met include selective coordination for multiple elevators (620.62) and hydraulic and some traction elevators with battery lowering [620.91(C)].

Safety considerations discussed on these two pages are selective coordination requirements for elevator circuits and hydraulic and some traction elevators with battery backup/auto recall.

620.62 Selective Coordination Elevator Circuits

NEC® Requirement under Article 620 which includes Elevators

For these elevator circuits, a design engineer must specify, the contractor must install, and the inspector should enforce main, feeder, sub-feeder, and branch circuit protective devices that are selectively coordinated for all possible values of overloads and short-circuits for the system.

One of the reasons that coordination is so important is because firefighters commonly use the elevator to get closer to a fire during fire-fighting operations and elevators are a means of egress in emergencies. When more than one driving machine is fed from a single feeder, selective coordination is required between the overcurrent protective device (OCPD) in each disconnecting means and any other supply side overcurrent protective devices. This requires all the overcurrent protective devices from the elevator disconnect to the main to be selectively coordinated with one another. For a brief discussion as to what selective coordination means go to page 8 in this publication. For a more in-depth discussion, reference the Cooper Bussmann SPD Selecting Protective Devices publication (download from www.bussmann.com).

For example, in Figures 1 and 2, if a fault were to occur on B1, B2, B3 or B4 (or F4) that would cause overcurrent protective devices F2 or M1 to open in Figure 1 and F1, F2, F3, or M1 to open in Figure 2. If M1 opens, the entire system is blacked out; most are all of the elevators in the building would lose power. If a fault were to occur on F2 that would cause M1 to open, all of the elevators in the building would

lose power. These conditions described are a lack of selective coordination and not in compliance with 620.62. Note, in attempt to get around the 620.62 requirement for Figure 1, some designers incorrectly believe the scheme in Figure 2 does not require selective coordination. For the layout in Figure 2, 620.62 requires F1, F2, F3, and F4 to be selectively coordinated with M1.

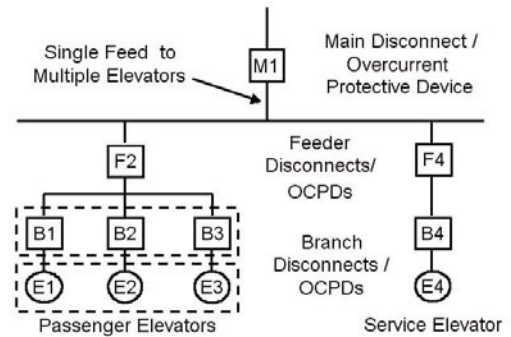

Figure 1

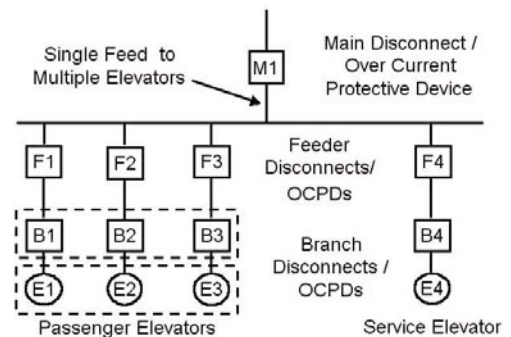

Figure 2

620.91 Emergency & Standby Power Systems (C) Disconnecting Means (Elevators)

The elevator disconnecting means referenced in NEC® 620.51, for maintenance purposes, must be capable of disconnecting all sources of power including those on the load side of the elevator. NEC® 620.91(C) covers elevators, which have an emergency power supply on the load side of the elevator disconnecting means required per NEC® 620.51. NEC® 620.91(C) requires removal of all sources of power including those on the load side of the elevator disconnecting means. Hydraulic and traction elevators have the capability

of using a battery pack to lower the elevator in a loss of power situation. The battery attachment is utilized as an extra level of safety to keep from stranding people in the elevator for long periods of time. For instance with hydraulic elevators under normal operation, the main line power from the disconnecting means controls the raising of the elevator through a pump motor and the lowering of the elevator through a solenoid and a drain valve. To send the cab upward, the pump motor pumps hydraulic fluid into the piston that forces the elevator upward. To return the cab

back down, a drain valve at the bottom of the piston is opened by a solenoid valve and as the fluid drains back into the reservoir, the elevator lowers. If the main line power is lost, this battery pack attachment can supply enough power to actuate the solenoid.

For the battery backup feature to operate properly, auxiliary contacts need to be in the controller and the disconnecting means. In addition, the disconnect/overcurrent protection in conjunction with the auxiliary contact must function properly for various operating scenarios. See Figure 3 has an illustrative diagram. A complete explanation of the various operating scenarios can not be presented in this publication. Go to www.bussmann.com under Product Info/Power Module to find a complete explanation.

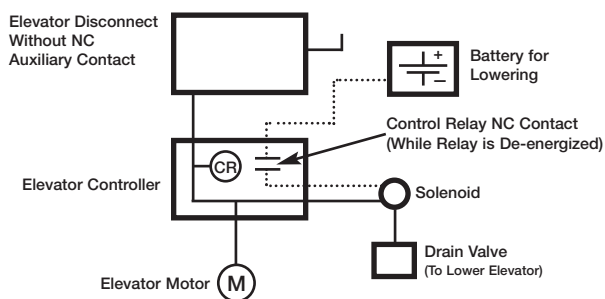

Figure 3 Normal Operation per NEC® 620.91(C) – this complies

It is important to recognize that the type disconnect used for the elevator shunt-trip device has a direct bearing on whether the battery backup functions as intended and whether the systems complies with 620.91(C). If not, there may be a safety hazard. There typically are three options considered for shunt-trip elevator disconnects with integral auxiliary contacts. Only one of these three work properly for elevators with battery backup for all scenarios:

1. Fusible shunt-trip switch with auxiliary contacts – (Cooper Bussmann Power Module™)
2. Fusible shunt-trip molded case switch (with an instantaneous trip override) with auxiliary contacts
3. Shunt-trip molded case circuit breaker with auxiliary contacts

Only the first option, the fusible shunt-trip switch with auxiliary contacts, provides the proper functioning if there is an overcurrent that opens one or more fuses in the disconnect. In this case the fuse(s) open resulting in a loss of power for

one or more phases, but the auxiliary contacts in the disconnect do not change state. So the battery backup function can work as intended.

For options 2 and 3, a branch circuit overcurrent that causes them to open may open the auxiliary contact and not allow battery backup to function as intended, which may be a safety issue. The molded case switch, option 2, has an instantaneous trip override that operates at a certain overcurrent level and beyond. When such an overcurrent occurs, the switch opens and the auxiliary contact opens. So for an overcurrent condition with option 2, the fusible molded case switch, may open and battery backup does not operate as intended. Whenever the molded case breaker, option 3, clears an overcurrent, the circuit opens and the auxiliary contact opens. Option 1 is the only option that properly operates and doesn't strand passengers.

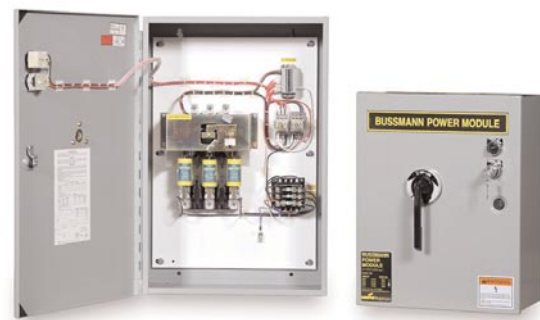

The POWER MODULE™ contains a shunt trip fusible switch together with the components necessary to comply with the fire alarm system requirements and shunt trip control power all in one UL Listed package. For engineering consultants this means a simplified specification. For contractors this means a simplified installation because all that has to be done is connecting the appropriate wires. For inspectors this becomes simplified because everything is in one place with the same wiring every time. The fusible portion of the switch utilizes LOW-PEAK® LPJ-(amp)SP fuses that protect the elevator branch circuit from the damaging effects of short-circuit currents as well as helping to provide an easy method of selective coordination when supplied with upstream LOW-PEAK fuses with at least a 2:1 amp rating ratio. More information about the Bussmann POWER MODULE™ can be found at www.bussmann.com. Note the POWER MODULE™ only accepts Class J fuses which have a physical size rejection feature (only Class J fuses accepted) and Class J fuses have 200,000A or 300,000A interrupting rating.

Cooper Bussmann Products And Technical Support Delivered Worldwide

Customer Assistance

Customer Satisfaction Team

The Cooper Bussmann Customer Satisfaction Team is available to answers questions regarding Bussmann® products and services. Calls should be made between 8:00 a.m. – 4:30 p.m. Central Time for all US time zones.

The Customer Satisfaction Team can be reached via:

- Phone: 636-527-3877
- Toll-free fax: 800-544-2570
- E-mail: fusebox@buss.com

Emergency and After-Hours Orders

To accommodate time-critical needs, Cooper Bussmann offers emergency and after-hours service for next flight out or will call. Customers pay only standard price for the circuit protection device, rush freight charges and a modest emergency fee for this service. Emergency and after-hours orders should be placed through the Customer Satisfaction Team. Call:

- 8:00 a.m.-4:30 p.m. Central Time 636-527-3877
- After hours 314-995-1342

Application Engineering

Application Engineering assistance is available to all customers. The Application Engineering team is staffed by degreed electrical engineers and available by phone with technical and application support Monday – Friday, 8:00 a.m. – 5:00 p.m. Central Time.

Application Engineering can be reached via phone, fax or email:

- Phone: 636-527-1270
- E-mail: fusetech@buss.com

Web Services

www.bussmann.com

The Cooper Bussmann web site makes available free information and other resources that include:

- Product Data Sheets for complete technical information on Bussmann products
- Online catalogs for the latest United States and European products
- Safety BASICs™ for the essentials of electrical safety
- Training Modules for increasing skill levels of customers and end users
- Fuse Cross Reference to find the correct Bussmann replacement for a competitive fuse
- Arc-Flash Calculator to determine the incident energy level and flash protection boundary along with the recommends the level of Personal Protective Equipment (PPE)

Your Authorized Bussmann Distributor is:

