

PREVENTIVE MAINTENANCE AND RELIABILITY OF LOW-VOLTAGE OVERCURRENT PROTECTIVE DEVICES

Dennis K. Neitzel, CPE (S.M. IEEE)
AVO Training Institute, Inc.
4271 Bronze Way
Dallas, Texas 75237

Dan Neeser (S.M. IEEE)
Cooper Bussmann
PO Box 14460
St. Louis, MO 63178-4460

Abstract – Electrical preventive maintenance and testing is one of the most important aspects to assuring the reliability and integrity of electrical distribution systems and equipment. It is also important for the protection of employees, or people in general. However, preventive maintenance of electrical systems and equipment, specifically with regard to overcurrent protective devices, is often overlooked or performed infrequently.

This paper will explore:

- Guides for electrical equipment and low-voltage overcurrent protective device maintenance and testing.
- Analysis of various electrical equipment installations and the maintenance program for low-voltage overcurrent protective devices practiced.
- Failure statistics for low-voltage overcurrent protective devices
- The reliability and integrity of low-voltage overcurrent protective devices.
- Arc flash hazards with respect to preventive maintenance of low-voltage overcurrent protective devices.
- Frequency of Maintenance Considerations for low-voltage circuit breakers.

I. INTRODUCTION

The *National Electrical Code* states "Overcurrent protection for conductors and equipment is provided to open the circuit if the current reaches a value that will cause an excessive or dangerous temperature in conductors or conductor insulation." [7]

With regard to circuit breakers, the only way to accomplish this is through proper maintenance and testing of these devices. Several studies have revealed that if a circuit breaker has not been maintained, according to the manufacturers' instructions, for a period of five years, there is a 50% probability of failure of the circuit breaker.

The first step to properly maintaining electrical equipment and overcurrent protective devices is to understand and practice recommendations of electrical equipment maintenance from various sources. Examples of sources that could be used for this purpose include, but are not limited to, NFPA 70B, IEEE Standard 902 (Yellow Book), NEMA AB-4, NETA Specs, NFPA 70E-Chapter 2, and the Manufacturer's instructions.

II. ELECTRICAL EQUIPMENT AND OVERCURRENT PROTECTIVE DEVICE MAINTENANCE AND TESTING

A. Qualified Employees

The first step required in the maintenance and testing of overcurrent protective devices is to provide adequate training and qualification for the employees who are required to perform this work. Paragraph 205.1 of NFPA 70E states: "Employees who perform maintenance on electrical equipment and installations shall be qualified persons...and shall be trained in and familiar with the specific maintenance procedures and tests required." [6]

Article 100 of NFPA 70E and the National Electrical Code (NEC) provides an excellent definition of a qualified person as: "One who has skills and knowledge related to the construction and operation of the electrical equipment and installations and has received safety training on the hazards involved." [7] The Occupational Safety and Health Administration (OSHA) also requires an employee to demonstrate proficiency in the work practices involved before the employer can certify that they have been trained. It is vitally important that an employee be properly trained and qualified to maintain electrical equipment in order to increase the equipment and system reliability, as well as the employee's safety.

B. Electrical Preventive Maintenance Program

Paragraph 210.5 of NFPA 70E also states: "Protective devices shall be maintained to adequately withstand or interrupt available fault current." It goes on to state in Paragraph 225.3 that: "Circuit breakers that interrupt faults approaching their ratings shall be inspected and tested in accordance with the manufacturers' instructions." [6]

The second step is to have an effective Electrical Preventive Maintenance (EPM) program. NFPA 70B makes several very clear statements about an effective EPM program as follows:

- 4.1.1 "Electrical equipment deterioration is normal, but equipment failure is not inevitable. As soon as new equipment is installed, a process of normal deterioration begins. Unchecked, the deterioration process can cause malfunction or an electrical failure. Deterioration can be accelerated by factors such as a hostile environment, overload, or severe duty cycle. An effective EPM program identifies and recognizes these factors and provides measures for coping with them. "
- 4.1.2 "In addition to normal deterioration, there are other potential causes of equipment failure that can be detected and corrected through EPM. Among these are load

changes or additions, circuit alterations, improperly set or improperly selected protective devices, and changing voltage conditions.”

- 4.1.3 “Without an EPM program, management assumes a greatly increased risk of a serious electrical failure and its consequences.”
- 4.2.1 “A well-administered EPM program will reduce accidents, save lives, and minimize costly breakdowns and unplanned shutdowns of production equipment. Impending troubles can be identified — and solutions applied — before they become major problems requiring more expensive, time consuming solutions.” [1]

Paragraph 5.3.1 of IEEE Std. 902 states: “In planning an electrical preventive maintenance (EPM) program, consideration must be given to the costs of safety, the costs associated with direct losses due to equipment damage, and the indirect costs associated with downtime or lost or inefficient production.” [2]

Another issue that also must be discussed is the Flash Hazard Analysis. One of the key components of this analysis is the clearing time of the overcurrent protective devices. The primary focus of this paper will be low-voltage circuit breakers. Fuses, although they are overcurrent protective devices, do not have operating mechanisms that would require periodic maintenance and testing to ensure proper overcurrent operation; therefore, they will not be addressed in this paper. The primary focus will be the maintenance issues associated with circuit breakers. Whether concerned with the proper protection of equipment or of personnel, periodic maintenance and testing is essential. All maintenance and testing of electrical protective devices addressed here must be accomplished in accordance with the manufacturer’s instructions as a minimum. In the absence of the manufacturer’s instructions, the *NETA Maintenance Testing Specifications for Electrical Power Distribution Equipment and Systems* is an excellent source of information for performing the required maintenance and testing of these devices. Whichever method is used, the manufacturer’s time-current curves would be required in order to properly test each protective device to ensure the proper clearing time of the device.

1) Molded-Case Circuit Breakers: The need for inspection of molded-case breakers will vary depending on operating conditions. Suggested inspection and testing is defined in ANSI/NEMA AB 4, *Guidelines for Inspection and Preventive Maintenance of Molded-Case Circuit Breakers Used in Commercial and Industrial Applications*. As part of these guidelines, AB 4 also provides some basic procedures for the inspection and maintenance of molded-case circuit breakers, by qualified persons.

Generally, maintenance on molded-case circuit breakers is limited to proper mechanical mounting, electrical connections, and periodic manual operation. Most lighting, appliance, and power panel circuit breakers have riveted frames and are not designed to be opened for internal inspection or maintenance. All other molded-case circuit breakers, that are UL approved, are factory-sealed to prevent access to the calibrated elements. An unbroken seal indicates that the mechanism has not been tampered with and that it should function as

specified by UL. A broken seal voids the UL listing and the manufacturers’ warranty of the device. In this case, the integrity of the device would be questionable. The only exception to this would be a seal being broken by a manufacturer’s authorized facility.

Molded-case circuit breakers receive initial testing and calibration at the manufacturers’ plants. These tests are performed in accordance with UL 489, *Standard for Safety, Molded-Case Circuit Breakers, Molded-Case Switches and Circuit Breaker Enclosures*. Molded-case circuit breakers, other than the riveted frame types, are permitted to be reconditioned and returned to the manufacturer’s original condition. In order to conform to the manufacturer’s original design, circuit breakers must be reconditioned according to recognized standards. An example of a recognized standard is the Professional Electrical Apparatus Recyclers League (PEARL) Reconditioning Standards. In order to ensure equipment reliability it is highly recommended that only authorized professionals recondition molded-case circuit breakers.

Circuit breakers installed in a system are often forgotten. Even though the breakers have been sitting in place supplying power to a circuit for years, there are several things that can go wrong. The circuit breaker can fail to open due to a burned out trip coil or because the mechanism is frozen due to dirt, dried lubricant, or corrosion. The overcurrent device can fail due to inactivity or a burned out electronic component. Many problems can occur when proper maintenance is not performed and the breaker fails to open under fault conditions. This combination of events can result in fires, damage to equipment, or injuries to personnel.

Common sense, as well as manufacturers’ literature, must be used when maintaining circuit breakers. Most manufacturers, as well as NFPA 70B, recommend that if a molded-case circuit breaker has not been operated, opened or closed, either manually or by automatic means, within as little as six months time, it should be removed from service and manually exercised several times. This manual exercise helps to keep the contacts clean, due to their wiping action, and ensures that the operating mechanism moves freely. This exercise however does not operate the mechanical linkages in the tripping mechanism (Figure 1). The only way to properly exercise the entire breaker operating and tripping mechanisms is to remove the breaker from service and test the overcurrent and short-circuit tripping capabilities. A stiff or sticky mechanism can cause an unintentional time delay in its operation under fault conditions. This could dramatically increase the arc/flash incident energy level to a value in excess of the rating of personal protective equipment.

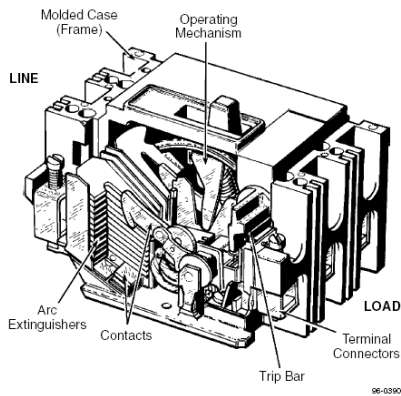

Figure 1
Principle Components

Another consideration is addressed by NFPA 70E, Paragraph 130.6(K) and OSHA in 29 CFR 1910.334(b)(2) which states:

“Reclosing circuits after protective device operation. After a circuit is deenergized by a circuit protective device, the circuit may NOT be manually reenergized until it has been determined that the equipment and circuit can be safely reenergized. The repetitive manual reclosing of circuit breakers or reenergizing circuits through replaced fuses is prohibited.

NOTE: When it can be determined from the design of the circuit and the overcurrent devices involved that the automatic operation of a device was caused by an overload rather than a fault condition, no examination of the circuit or connected equipment is needed before the circuit is reenergized.”

The safety of the employee manually operating the circuit breaker is at risk if the short circuit condition still exists when reclosing the breaker. OSHA no longer allows the past practice of resetting a circuit breaker one, two, or three times before investigating the cause of the trip. This previous practice has caused numerous burn injuries that resulted from the explosion of electrical equipment. **BEFORE** resetting a circuit breaker, it, along with the circuit and equipment, must be tested and inspected, by a qualified person, to ensure a short circuit condition does not exist and that it is safe to reset the breaker.

Any time a circuit breaker has operated and the reason is unknown, the breaker, circuit, and equipment must be inspected for a short circuit condition. Melted arc chutes will not interrupt fault currents. If the breaker cannot interrupt a second fault, it will fail and may destroy its enclosure and create a hazard for anyone working near the equipment.

To further emphasize this point the following quote from an article written by a NEMA representative is provided:

“After a high level fault has occurred in equipment that is properly rated and installed, it is not always clear to investigating electricians what damage has occurred inside encased equipment. The circuit breaker may well appear virtually clean while its internal condition is unknown. For such situations, the NEMA AB4 ‘Guidelines for Inspection and Preventive Maintenance of MCCBs Used in Commercial and Industrial Applications’ may be of help. Circuit breakers unsuitable for continued service may be identified by simple

inspection under these guidelines. Testing outlined in the document is another and more definite step that will help to identify circuit breakers that are not suitable for continued service.

After the occurrence of a short circuit, it is important that the cause be investigated and repaired and that the condition of the installed equipment be investigated. A circuit breaker may require replacement just as any other switching device, wiring or electrical equipment in the circuit that has been exposed to a short circuit. Questionable circuit breakers must be replaced for continued, dependable circuit protection.” [10]

The condition of the circuit breaker must be known to ensure that it functions properly and safely before it is put it back into service.

2) Low-Voltage Power Circuit Breakers: Low-voltage power circuit breakers are manufactured under a high degree of quality control, of the best materials available, and with a high degree of tooling for operational accuracy. Manufacturer’s tests, per UL 1066 *Low-Voltage AC and DC Power Circuit Breakers Used in Enclosures*, show these circuit breakers to have durability beyond the minimum standards requirements. All of these factors give these circuit breakers a very high reliability rating when proper maintenance is performed per the manufacturer instructions. However, because of the varying application conditions and the dependence placed upon them for protection of electrical systems and equipment as well as the assurance of service continuity, inspections and maintenance checks must be made on a regular basis. Several studies have shown that low-voltage power circuit breakers, which were not maintained within a 5-year period, have a 50% failure rate.

Maintenance of these breakers will generally consist of keeping them clean and properly lubricated. In addition, it is also necessary to periodically check the circuit breaker contacts for wear and alignment and inspect the circuit breaker arc chutes, especially after opening a fault condition. In fact, manufacturers recommend that these breakers be thoroughly inspected prior to reclosing the circuit breaker after interruption of a fault condition. The frequency of maintenance will depend to some extent on the cleanliness and environmental conditions of the surrounding area. If there were very much dust, lint, moisture, or other foreign matter present then more frequent maintenance would be required.

Industry standards for, as well as manufacturers of, low-voltage power circuit breakers recommend a general inspection and lubrication after a specified number of operations or at least once per year, whichever comes first. Some manufacturers also recommend this same inspection and maintenance be performed after the first six months of service for a new circuit breaker, regardless of the number of operations. If the breaker remains open or closed for a long period of time, it is recommended that arrangements be made to open and close the breaker several times in succession. Environmental conditions would also play a major role in the scheduling of inspections and maintenance. If the initial inspection indicates that maintenance is not required at that time, the period may be extended to a more economical point. However, more frequent inspections and maintenance may be required if severe load conditions exist or if an inspection reveals heavy accumulations of dirt, moisture, or other foreign matter that might cause mechanical, insulation, or electrical

failure. Mechanical failure would include an unintentional time delay in the circuit breakers tripping operation due to dry, dirty, or corroded pivot points or by hardened or sticky lubricant in the moving parts of the operating mechanism. The manufacturer's instructions must be followed in order to minimize the risk of any unintentional time delay.

Figure 2 provides an illustration of the numerous points where lubrication would be required and where dirt, moisture, corrosion or other foreign matter could accumulate causing a time delay in, or complete failure of, the circuit breaker operation.

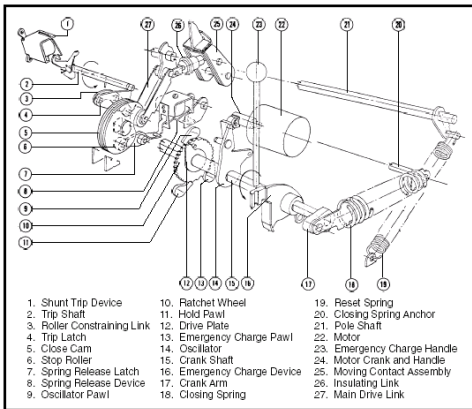

Figure 2
Power-Operated Mechanism

III. ANALYSIS OF ELECTRICAL EQUIPMENT INSTALLATIONS AND MAINTENANCE PROGRAMS PRACTICED FOR LOW-VOLTAGE OVERCURRENT PROTECTIVE DEVICES

In testing a variety of low-voltage power circuit breakers in a manufacturing facility there were several failures that occurred. Nine circuit breakers were removed from service in order to perform testing of their tripping capabilities. One breaker tripped according to the manufacturer's time-current curves for the trip device. Two of the breakers tripped before the test current reached the long-time trip setting value. The remaining six breakers would not trip, regardless of the amount of primary injection current applied to them. Further investigation revealed that these nine circuit breakers were last tested and maintained five to eight years previous. It should also be noted that the breaker mechanisms had been lubricated with a penetrant rather than a lubricant. Penetrants are not lubricants and they become extremely sticky in a very short period of time. A sticky operating mechanism will generally cause excessive time delays in the operation of the circuit breaker. In six of the nine breakers noted, the operating mechanism did not work due to improper lubrication. If these breakers were called upon to open a circuit under fault conditions they would fail, equipment would be damaged or destroyed, unnecessary downtime would occur, and employee's lives would be put in jeopardy.

In another industrial facility it was reported that it was not uncommon to have a time delay of several seconds or in some cases minutes from the time a trip button was pushed until the breaker finally opened.

IV. FAILURE STATISTICS FOR LOW-VOLTAGE OVERCURRENT PROTECTIVE DEVICES

Several studies on electrical equipment failures have been completed over the years by IEEE. These studies have generated failure statistics on electrical distribution system equipment and components. IEEE Std. 493-1997 (Gold Book) "IEEE Recommended Practice for the Design of Reliable Industrial and Commercial Power Systems" contains the information and statistics from these studies and can be used to provide failure data of electrical equipment and components such as low-voltage circuit breakers. The primary study that this paper will focus on was conducted in 1974. However, the results from a more recent study, completed in 1996, will also be given.

One key study that was completed and yields reliability data on circuit breakers was completed in 1974. These study results were based upon low and medium voltage power circuit breakers (drawout and fixed) and fixed mounted molded case circuit breakers. The results of the study indicated:

- 32% of all circuit breakers failed while in service.
- 9% of all circuit breakers failed while opening.
- 7% of all circuit breakers failed due to damage while successfully opening.
- 42% of all circuit breakers failed by opening when it should not have opened.
- 77% of fixed mounted circuit breakers (0-600V including molded case) failed while in service.
- 18% of all circuit breakers had a mechanical failure
- 28% of all circuit breakers had an electric-protective device failure.
- 23% of all circuit breaker failures were suspected to be caused by manufacturer defective component.
- 23% of all circuit breaker failures were suspected to be caused by inadequate maintenance.
- 73% of all circuit breaker failures required round-the-clock all-out efforts.

A 1996 IEEE survey was conducted on low-voltage power circuit breakers and the results concluded:

- 19.4% of low-voltage power circuit breakers with electromechanical trip units had unacceptable operation.
- 10.7% of low-voltage power circuit breakers with solid-state trip units had unacceptable operation.

V. RELIABILITY AND INTEGRITY OF LOW-VOLTAGE OVERCURRENT PROTECTIVE DEVICES

Reviewing the data from the IEEE studies, it can be seen that nearly 1/3 of all circuit breakers failed while in service and thus would not have been identified unless proper maintenance was performed. In addition, 16% of all circuit breakers failed or were damaged while opening. Thus, if proper maintenance was not completed these may have caused a serious safety issue, especially if the circuit breaker was attempted to be re-closed without performing needed maintenance. The fact that 42% of all circuit breakers failed by opening when it should not have opened suggests improper circuit breaker settings or a lack of selective coordination. This type of circuit breaker

failure can significantly affect plant processes and could result in a total plant shutdown.

Also of significance is that a very large percentage of fixed mounted circuit breakers, including molded case had a very high failure rate of 77%. This is most likely due to the fact that maintenance of this style of device is often overlooked, but certainly just as important.

The fact that 18% of all circuit breakers had a mechanical failure and 28% of all circuit breakers had an electric-protective device failure suggests that both the mechanical linkages as well as the trip units need to be maintained. Furthermore, although mechanical maintenance is important, proper testing of the trip unit is much more critical.

Also of importance to the user, is the realization that maintenance and testing is needed due to the fact that nearly ¼ of all circuit breaker failures were caused by a manufacturer defective component and nearly another ¼ of all circuit breaker failures were due to inadequate maintenance. Thus, if proper maintenance and testing is performed, potentially 50% of the failures could be eliminated or identified before a problem occurs. But perhaps the most important issue for an end user is downtime. With regard to this concern, the study indicated 73% of all circuit breaker failures required round-the-clock all-out efforts. This could most likely be greatly reduced if preventive maintenance was performed.

The results from the 1996 IEEE study show that technology has improved the failure rate of low-voltage power circuit breakers and could potentially be cut by almost half, but maintenance and testing is still needed.

VI. ARC FLASH HAZARD CONSIDERATIONS

Maintenance and testing is also essential to ensure proper protection of equipment and personnel. With regard to personnel protection, Paragraphs 110.8(B)(1)(b) and 130.3 of NFPA 70E require a flash hazard analysis be performed before anyone approaches exposed electrical conductors or circuit parts that have not been placed in an electrically safe work condition. In addition it requires a flash protection boundary be established. All calculations for determining the personal protective equipment based on the incident energy of an arc, and for establishing a flash protection boundary, require the arc clearing time. This clearing time is derived from the engineering coordination study which is based on what the protective devices are supposed to do.

If, for example, a low-voltage power circuit breaker had not been operated or maintained for several years and the lubrication had become sticky or hardened, the circuit breaker could take several additional cycles, seconds, minutes, or longer to clear a fault condition. The following are specific examples based on equations from NFPA 70E Annex D:

Two Flash Hazard Analyses will be performed using a 20,000-amp short-circuit with the worker distance of 18 inches from the arc:

1. Based on what the system is supposed to do:
 - 0.1 second (6 cycles)
2. Due to a sticky mechanism the breaker now has an unintentional time delay:
 - 0.5 second (30 cycles)

Example #1:

E_{MB} = maximum 20 in. cubic box incident energy, cal/cm²

D_B = distance from arc electrodes, inches (for distances 18 in. and greater)

t_A = arc duration, seconds

F = short circuit current, kA (for the range of 16 kA to 50 kA)

(1) D_A = 18 in.

(2) t_A = 0.1 second (6 cycles)

(3) F = 20kA

$$\begin{aligned} E_{MB} &= 1038.7D_B^{-1.4738} t_A [0.0093F^2 - 0.3453F + 5.9675] \\ &= 1038 \times 0.0141 \times 0.1 [0.0093 \times 400 - 0.3453 \times 20 + 5.9675] \\ &= 1.4636 \times [2.7815] \\ &= 4.071 \text{ cal/cm}^2 \end{aligned}$$

NFPA 70E, Table 130.7(C)(11) requires Category 1 protection (FR shirt and FR pants or FR coverall) plus a hard hat and safety glasses.

Example #2:

E_{MB} = maximum 20 in. cubic box incident energy, cal/cm²

D_B = distance from arc electrodes, inches (for distances 18 in. and greater)

t_A = arc duration, seconds

F = short circuit current, kA (for the range of 16 kA to 50 kA)

(1) D_A = 18 in.

(2) t_A = 0.5 second (30 cycles)

(3) F = 20kA

$$\begin{aligned} E_{MB} &= 1038.7D_B^{-1.4738} t_A [0.0093F^2 - 0.3453F + 5.9675] \\ &= 1038 \times 0.0141 \times 0.5 [0.0093 \times 400 - 0.3453 \times 20 + 5.9675] \\ &= 7.3179 \times [2.7815] \\ &= 20.3547 \text{ cal/cm}^2 \end{aligned}$$

NFPA 70E, Table 130.7(C)(11) requires Category 3 protection (cotton underwear plus FR shirt and FR pants plus FR coverall, or cotton underwear plus two FR coveralls) Category 3 also requires a hard hat, safety glasses or goggles, flash suit hood, hearing protection, leather gloves, and leather work shoes. [6]

If the worker is protected based on what the circuit breaker is supposed to do (0.1 second or 6 cycles) and an unintentional time delay occurs (0.5 second or 30 cycles), the worker could be seriously injured or killed

because he/she was under protected. In addition, the arc blast hazard would also increase as the incident energy increases from 4 cal/cm² to 20 cal/cm².

As can be seen, circuit breaker maintenance is extremely important to an electrical safety program. Maintenance must be performed according to the manufacturer's instructions in order to minimize the risk of having an unintentional time delay in the operation of the circuit protective devices.

VI. FREQUENCY OF MAINTENANCE CONSIDERATIONS

The frequency of maintenance is also a very important consideration. 21.4 of NFPA 70B recommend a typical range of equipment maintenance from 6 months to 3 years, depending upon equipment condition and use. NETA also publishes a document to determine the recommended frequency of maintenance. This document is MTS-2001 Appendix B Frequency of Maintenance Tests. In the NETA document, the frequency of maintenance depends on the type of inspection and testing. This can include visual, mechanical, and electrical. The recommended frequency of maintenance for these types of inspections can be further refined based upon equipment reliability requirements and equipment condition.

By referring to the NETA document it can be determined that the frequency of maintenance for low voltage circuit breakers, assuming a medium reliability factor and average equipment condition would be visual inspection every month, visual and mechanical inspection and testing every 12 months and visual, mechanical and electrical inspection and testing every 36 months. However, if the equipment reliability requirement was increased to high, these inspection and testing intervals would be cut in half.

CONCLUSION

In order to protect electrical equipment and people, proper electrical equipment preventive maintenance must be performed. Several standards and guides exist to assist users with electrical equipment maintenance. Provided the overcurrent protective devices are properly maintained, checked and tested for proper calibration and operation, equipment damage and arc flash hazards can be limited as expected.

REFERNECES

- [1] NFPA 70B, Recommended Practice for Electrical Equipment Maintenance, 2006 Edition
- [2] IEEE Standard 902-1998 (Yellow Book), Guide for Maintenance, Operation, and Safety of Industrial and Commercial Power Systems
- [3] NEMA Standard AB 4, Guidelines for Inspection and Preventive Maintenance of Molded Case Circuit Breakers Used in Commercial and Industrial Applications

- [4] IEEE Standard 493-1997 (Gold Book), Recommended Practice For The Design Of Reliable Industrial And Commercial Power Systems
- [5] IEEE Standard 1015-1997 (Blue Book), Recommended Practice For Applying Low-Voltage Circuit Breakers Used In Industrial And Commercial Power Systems
- [6] NFPA 70E, Standard for Electrical Safety in the Workplace, 2004 Edition
- [7] NFPA 70, National Electrical Code
- [8] IEEE Standard 1584-2002, Guide for Arc Flash Hazard Calculations
- [9] NETA, Maintenance Testing Specifications for Electrical Power Distribution Equipment and Systems 2001 Edition
- [10] National Equipment Manufacturer's Association (NEMA) Vince A. Baclawski, Technical Director, Power Distribution Products, NEMA; EC&M magazine, pp. 10, January 1995
- [11] Manufacturer's Instruction Books

AUTHOR'S BIOGRAPHY

Dennis K. Neitzel, CPE (Senior Member, IEEE) Mr. Neitzel is the Director of AVO Training Institute, Inc. (a Subsidiary of Megger); Dallas, Texas. Mr. Neitzel earned his Bachelor's degree in Electrical Engineering Management and his Master's degree in Electrical Engineering Applied Sciences. He is an active member of IEEE, ASSE, NFPA, AFE, and IAEI. He is a Certified Plant Engineer and a Certified Electrical Inspector. Mr. Neitzel serves as a Principal Committee Member for the NFPA 70E, "*Standard for Electrical Safety in the Workplace*", is co-author of the *Electrical Safety Handbook*, McGraw-Hill Publishers, and is the Working Group Chairman for revising IEEE Std. 902 (the Yellow Book), "*IEEE Guide for Maintenance, Operation, and Safety of Industrial and Commercial Power Systems*". Mr. Neitzel serves as the Vice-Chairman of the IEEE-PPIC-TSSC Sub-Committee.

Dan Neeser (S.M. IEEE) Dan Neeser is employed by Cooper Bussmann and holds the title of Senior Technical Sales Engineer. He participates in IEEE, NEMA, NFPA, NJATC, IBEW, NECA, and IAEI activities. He is currently the Chair of the IEEE Industrial and Commercial Power Systems (I&CPS) Department of the Industry Applications Society (IAS). He specializes in training on the design and application of overcurrent protective devices in electrical distribution systems in accordance with the National Electrical Code. Prior to his position with Cooper Bussmann, he was a Sales Engineer for Cutler-Hammer focusing on construction project sales of electrical distribution products. He has a BSME from the University of North Dakota.