

## New Assembly Short-Circuit Current Rating (SCCR) Marking Requirements

The 2005 NEC® has new requirements for the following equipment to be marked with a short-circuit current rating:

- Industrial Control Panels NEC® 409.110
- Industrial Machinery Electrical Panels NEC® 670.3(A)
- Certain HVAC Equipment NEC® 440.4(B)
- Meter Disconnect Switches NEC® 230.82(3)
- Certain Motor Controllers NEC® 430.8

### Significance of This Change:

The new 2005 NEC® short-circuit current rating marking requirements facilitate the inspection and approval process. The marking of a short-circuit current rating, ensuring a key piece of information needed for a safer installation, is required to be provided, see Figure 1. The change from marking the interrupting rating of the main overcurrent protective device or no marking at all, to a marking for the component or assembly short-circuit current rating is a much needed revision. This change clarifies the uncertainty associated with past short-circuit markings that users incorrectly assumed were representative of the entire assembly when in fact they were only an interrupting rating of the main overcurrent protective device. By providing a short-circuit current rating representative of the assembly, the procedure for ensuring compliance with Section 110.10 is simplified. Short-circuit current ratings marked on components and equipment make it easier to verify proper overcurrent protection for components and equipment for specific applications whether it be the initial installation or relocation of equipment.

### Why The Change

Varying, but similar reasons were provided for these changes, however they all had one goal, to ensure a safe installation through compliance with NEC® 110.10 while simplifying the inspection and approval process. A major substantiation for this new requirement was that control panels are being misapplied in a large number of applications because they have an inadequate short-circuit current rating. These misapplications often result because industrial control panels have unique conditions surrounding them. The table below shows some of these conditions and how the new requirements help.

### New Marking Requirements Simplify NEC® 110.10 Compliance

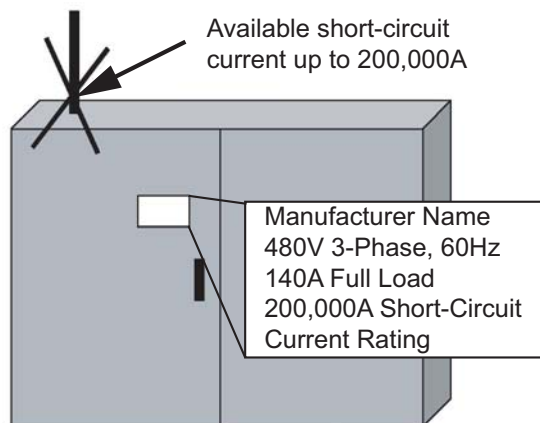

**Industrial Control Panel**

**Figure 1. — With the new equipment marking requirements, compliance with NEC® 110.10 is simplified.**

Unique Condition	Issue	How This New Requirement Helps
Industrial control panels can be moved around from installation to installation.	This movement may result in varying electrical systems, environments, grounding means, and available short-circuit current levels. Therefore, it is critical to supply the ratings associated with the industrial control panel assembly via markings in order to ensure a safer installation.	By providing these markings, the installer can obtain the appropriate information needed to ensure a safer installation by comparing the short-circuit current rating of the equipment with the available short-circuit current.
Many industrial control panels are constructed by a manufacturer and installed by someone else.	Without an exchange of information between the installer and manufacturer, any special requirements associated with the panel will not be known by the installer and possibly cause an unsafe installation.	These new requirements ensure a proper exchange of information through equipment markings.
Many industrial control panels are field assembled and not assembled according to a product standard.	Compliance with field assembled control panels is a complex process that may lead to omissions and unsafe installations due to, but not limited to, the following: <ul style="list-style-type: none"> <li>• Confusion over appropriate requirements (NEC®, NFPA79, etc.) by assemblers</li> <li>• Increased demand on AHJs* to ensure compliance</li> </ul>	The new short-circuit current rating marking requirement ensures that field assembled panels where product standards are not used, are properly marked and lessens the burden on AHJs to ensure compliance with NEC® 110.10.
There are an increasing number and variety of components, devices, and equipment being used in industrial control panels.	The increased level of information needed to ensure proper application is a difficult process leading to oversights and unsafe installations.	These new marking requirements will help ensure that critical information needed for the proper application of the components, devices, and equipment being used in industrial control panels will be provided.

\* AHJ: Authority Having Jurisdiction

# Industrial Control Panels: Assembly SCCR Requirement

## Frequently Asked Questions

### What is a Short-Circuit Current Rating?

Short-circuit current ratings on components and equipment represent the maximum level of short-circuit current that the component or equipment can withstand and used for determining compliance with NEC® 110.10. This rating can be marked on individual components or assemblies. The new short-circuit current ratings required by NEC® 409.110, 440.4(B), and 670.3(A) represent the maximum amount of fault current that the assembly can withstand under short-circuit conditions. Assembly ratings take into account all components contained within the equipment rather than just the main overcurrent protective device.

**CAUTION:** Short-circuit current ratings are different than interrupting ratings marked on overcurrent protective devices. A common mistake is to assume that the interrupting rating of the overcurrent protective device protecting the circuit represents the short-circuit rating for the entire circuit, see Figure 3. Interrupting ratings, used for compliance with NEC® 110.9, are ratings for overcurrent devices. It is the characteristics of the overcurrent device (e.g. opening time, let-through energy, etc.) that need to be used in determining compliance with NEC® 110.10, not the interrupting rating, see Figure 2. However, overcurrent protective devices' interrupting ratings are one key factor in determining an assembly's short-circuit current rating.

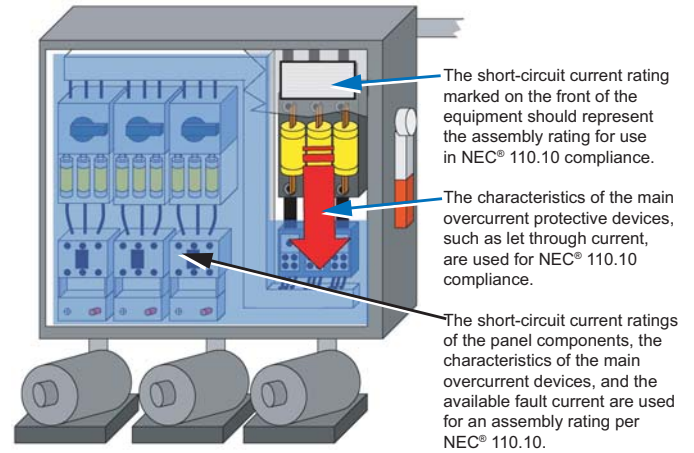

Figure 2.

### Why is the Short-Circuit Current Rating Marking Needed?

Inspectors and installers need this information in order to ensure compliance with Section 110.10. Equipment installed where short-circuit current levels exceed their short-circuit current rating can be hazardous to persons and property. Short-circuit current ratings marked on components and equipment make it easier to verify proper protection for components and equipment for specific applications whether it be the initial installation or relocation of equipment.

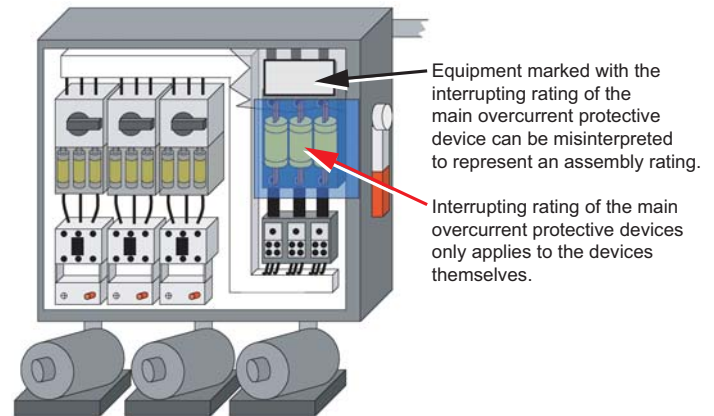

Figure3. — Interrupting ratings pertain ONLY to the overcurrent protective device

### How is it determined?

For meter disconnect switches and motor controllers, this withstand level or short-circuit current rating, is often determined by product testing. For assemblies, the marking can be determined through product listing or by an approved method. With the release of the UL508A Industrial Control Panel standard, an industry method is now available. Any method used, whether UL508A or another approved method, should be based on the "weakest link" approach. In other words, the assembly should be limited to installation where fault levels do not exceed the withstand rating of devices with the lowest short-circuit current rating, see Figure 4. The marking determined should represent the limits of the assembly for a safe installation. Current limiting overcurrent protective devices can be used to increase the assembly short-circuit current rating where lower rated components are used. When current limiting devices that limit short-circuit current levels to within the lower rated components rating are used, they provide protection for the assembly provided the current limiting overcurrent protective device is used within its ratings.

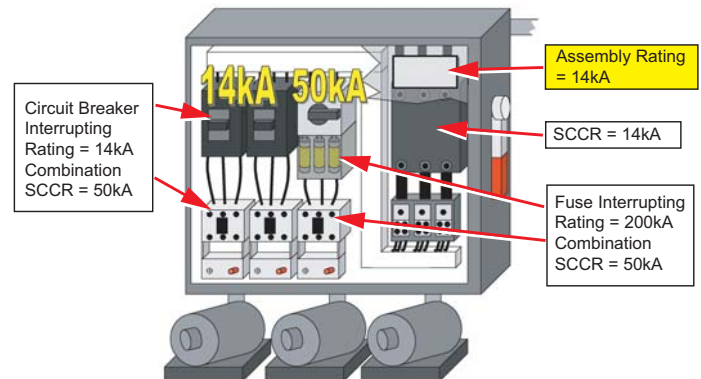

Figure 4. — Assembly short-circuit current rating limited to lowest rated device (14kA)

## Determining Assembly SCCR: Two Sweep Method

### Based Upon UL508A Supplement SB

#### SWEEP 1 —

#### Verifying Component Withstand Ratings for the Assembly

##### Step 1: Determine the Short-Circuit Current Rating for Each Branch Circuit

Verify all components' short-circuit current ratings and any special conditions that exist to utilize the ratings. If the component is not marked with a listed short-circuit current rating, use the default short-circuit current ratings mandated by the product standards (i.e.: UL508A Table SB4.1, Table SCCR1). Apply the lowest SCCR of any component used in the branch circuit as the SCCR of the branch circuit.

See **Table SCCR1** for default values on the next page.

Determine the lowest component short-circuit current rating for each branch circuit.

##### Step 2: Determine the Short-Circuit Current Rating for Each Feeder Circuit (*includes Mains, Feeders and Sub-feeders*)

Verify all component short-circuit current ratings and any special conditions that exist to utilize the ratings for each feeder circuit. If the component is not marked with a listed short-circuit current rating, use the default short-circuit current ratings mandated by the product standards (i.e.: UL508A Table SB4.1, Table SCCR1). Apply the lowest SCCR of any component used in the feeder circuit as the SCCR of the feeder circuit. Determine the lowest component short-circuit current rating for each feeder circuit.

##### Step 3: If using current limiting fuses in the feeder circuit, modify branch circuit and feeder circuit short-circuit current ratings.

If current limiting overcurrent protective devices are used in the feeder circuit, determine if any modifications to increase the short-circuit current rating of the downstream circuits can be established by applying the following procedure:

- a) If the overcurrent protective device in the feeder circuit is a current-limiting fuse, determine the peak let-through umbrella value dictated by the product standard for the fuse class and size utilized at the level of fault current desired (50, 100, 200kA).

See Table SCCR2 for UL Umbrella Limit Table

- b) Ensure that the peak let-through value is less than any of the short-circuit current ratings determined in Step 1 and any feeder components as determined in Step 2.
- c) If condition 3(b) is met, apply a short-circuit current rating to the feeder circuit and all branches fed by the feeder based upon the value of fault current (50kA, 100kA, 200kA) used to determine the peak let-through value of the current-limiting fuse.

##### Step 4: Determine the short-circuit current rating for Sweep 1

Determine the Sweep 1 short-circuit current rating by utilizing the short-circuit current rating of the lowest rated branch or feeder circuit. Retain for Sweep 2.

#### Sweep 2 —

#### Modifying Assembly Short-Circuit Current Ratings Based Upon Interrupting Ratings of Overcurrent Protective Devices

Determine the interrupting ratings of all the overcurrent protective devices used in the feeder and branch circuits. Compare them with the assembly short-circuit current rating from Sweep 1 Step 4. The lowest rating encountered is the assembly short-circuit current rating.

**IMPORTANT NOTE:** Often a high short-circuit current rating can be obtained utilizing the method in Sweep 1, only to be limited by the use of an overcurrent protective device in a branch or feeder circuit with an interrupting rating less than the desired assembly rating (i.e.: less than 50kA). A quick and easy solution to this problem would be to use overcurrent protective devices, such as current limiting fuses, in the branch circuits and feeders which have interrupting ratings at or above the desired short-circuit current rating for the assembly (i.e.: >50kA).

## Determining Assembly SCCR: Two Sweep Method

**Table: SCCR1**

Component	Short-Circuit Current Rating (kA)
Bus bars	10
Circuit breaker (including GFCI type)	5
Current meters	*
Current shunt	10
Fuse holder	10
Industrial control equipment	
a. Auxiliary devices (overload relay)	5
b. Switches (other than mercury tube type)	5
c. Mercury tube switches:	
• Rated over 60 amps or over 250 volts	5
• Rated 25 volts or less, 60 amps or less and over 5kVA	3.5
• Rated 250 volts or less and 2kVA or less	1
Motor controller, rated in horsepower (kW)	
a. 0-50 (0-37.5)	5**
b. 51-200 (38-149)	10**
c. 201-400 (150-298)	18**
d. 401-600 (299-447)	20**
e. 601-900 (448-671)	42**
f. 901-1500 (672-1193)	85**
Meter socket base	10
Miniature or miscellaneous fuse	10***
Receptacle (GFCI type)	2
Receptacle (other than GFCI)	10
Supplementary protector	0.2
Switch unit	5
Terminal block or power distribution block	10

\* A short-circuit current rating is not required when connected via a current transformer or current shunt. A directly connected current meter shall have a marked short-circuit current rating.

\*\* Standard fault current rating for motor controller rated within specified horsepower range.

\*\*\* The use of a miniature fuse is limited to 125 volt circuits.

## Determining Assembly SCCR: Two Sweep Method

Table: SCCR2

Fuse Types	Fuse Rating Amps	Between threshold & 50kA		100kA		200kA	
		$I^2t \times 10^3$	$I_p \times 10^3$ (kA)	$I^2t \times 10^3$	$I_p \times 10^3$ (kA)	$I^2t \times 10^3$	$I_p \times 10^3$ (kA)
Class CC	15	2	3	2	3	3	4
	20	2	3	3	4	3	5
	30	7	6	7	7.5	7	12
Class G	15	—	—	3.8	4	—	—
	20	—	—	5	5	—	—
	30	—	—	7	7	—	—
	60	—	—	25	10.5	—	—
Class T 300V	30	3.5	5	3.5	7	3.5	9
	60	15	7	15	9	15	12
	100	40	9	40	12	40	12
	200	150	13	150	16	150	20
	400	500	22	650	28	650	35
	600	1000	29	1000	37	1000	46
	800	1500	37	1500	50	1500	65
	1200	3500	50	3500	65	4000	80
Class J and Class T 600V	30	7	6	7	7.5	7	12
	60	30	8	30	10	30	16
	100	60	12	80	14	80	20
	200	200	16	300	20	300	30
	400	1000	25	1100	30	1100	45
	600	2500	35	2500	45	2500	70
	800*	4000*	50*	4000*	55*	4000*	75*
Class L	800	10000	80	10000	80	10000	80
	1200	12000	80	12000	80	15000	120
	1600	22000	100	22000	100	30000	150
	2000	35000	110	35000	120	40000	165
	2500	—	—	75000	165	75000	180
	3000	—	—	100000	175	100000	200
	4000	—	—	150000	220	150000	250
	5000	—	—	350000	—	350000	300
	6000	—	—	350000	—	500000	350
Class R		RK1 RK5	RK1 RK5	RK1 RK5	RK1 RK5	RK1 RK5	RK1 RK5
	30	10 50	6 11	10 50	10 11	11 50	12 14
	60	200 200	10 20	40 200	12 21	60 200	16 26
	100	500 500	14 22	100 600	16 25	100 500	20 32
	200	1600 1600	18 32	400 1600	22 40	400 2000	30 50
	400	5000 5000	33 50	1200 5000	35 60	1600 6000	50 75
	600	10000 10000	43 65	3000 10000	50 80	4000 12000	70 100

\* Value applies to Class T fuses.

Note: These are UL umbrella limits.

## Determining Assembly SCCR: Example

### EXAMPLE

The panel in Figure 5 will be used as an example of determining an assembly short-circuit current rating.

The 480V panel consists of:

1. Molded Case Circuit Breaker protecting an IEC starter
2. Combination Starter
  - +Instantaneous Trip Circuit Breaker (MCP)
  - +Motor Controller
  - +Overload Relay
  - +Special Assembly Conditions
3. Fusible Disconnect Switch protecting an IEC starter
4. Power Distribution Block
5. Current Limiting Class J 60A Fuses in the fusible disconnect

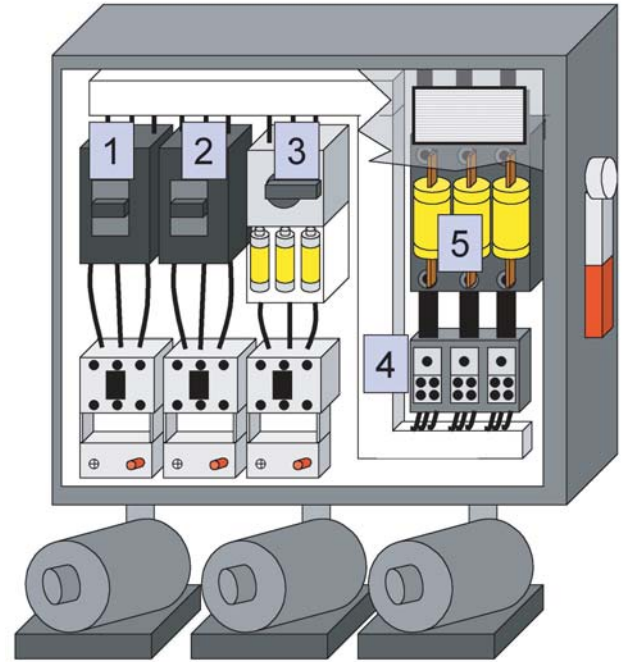

Figure 5.

The one line schematic and device descriptions are shown here:

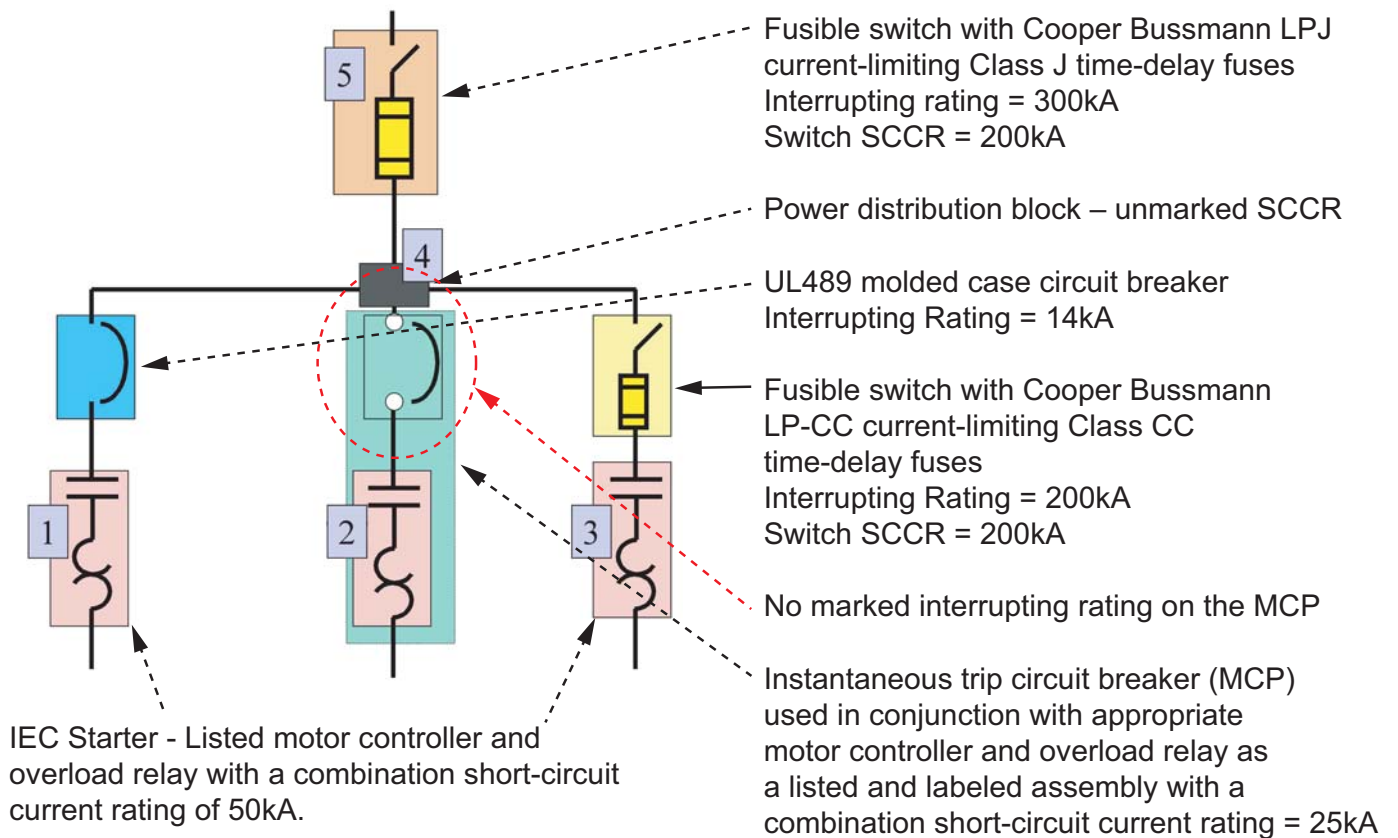

Figure 6.

## Determining Assembly SCCR: Example

### Find It, Fix It — Forget It

It's easy to comply with NEC® 110.10 and well worth the effort. Once you determine the assembly short-circuit current ratings in your equipment, you can take the necessary steps that follow to remedy marking requirements, and know you're in compliance.

### Sweep 1 — Step 1 - Branch 1

#### Determine the Short-Circuit Current Rating for Each Branch Circuit

Determine Short-Circuit Current Rating for Branch #1

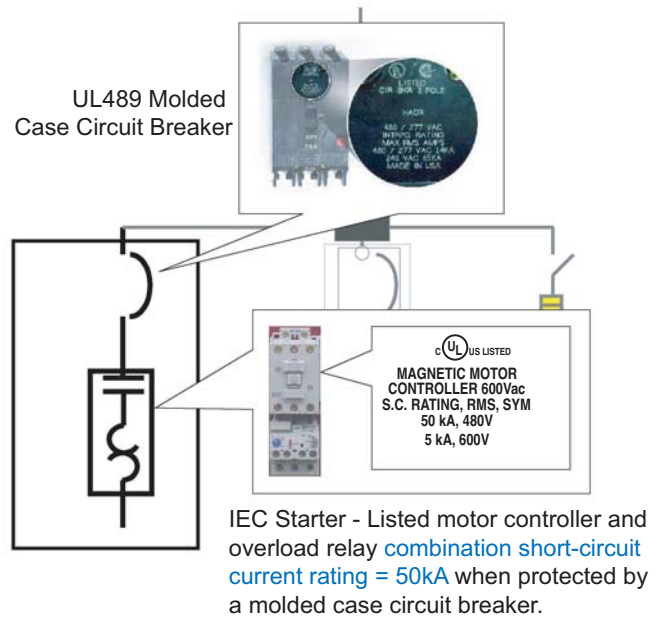

Figure 7.

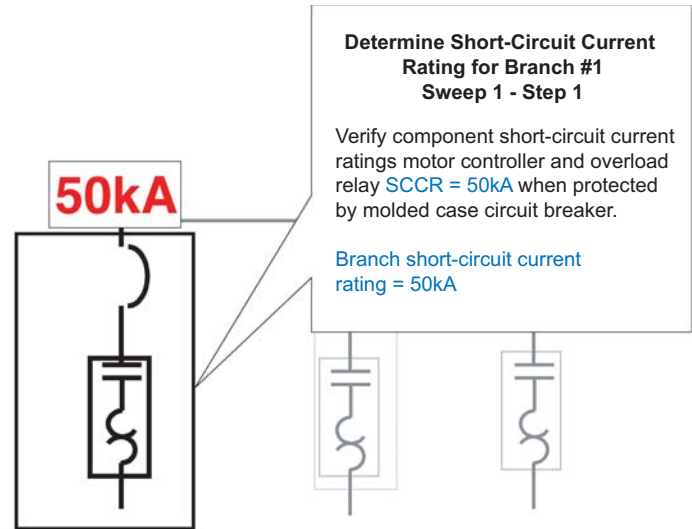

Figure 8. — Short-Circuit Current Rating for Branch 1 = 50kA

# Industrial Control Panels: Assembly SCCR Requirement

## Determining Assembly SCCR: Example

### Sweep 1 — Step 1 - Branch 2

#### Determine Short-Circuit Current Rating for Branch 2

Listed Combination Controller (Made up of a Motor Controller, Overload Relay, and Instantaneous Trip Circuit Breaker listed for use with each other as an assembly and applied according to the instructions included in the listing.

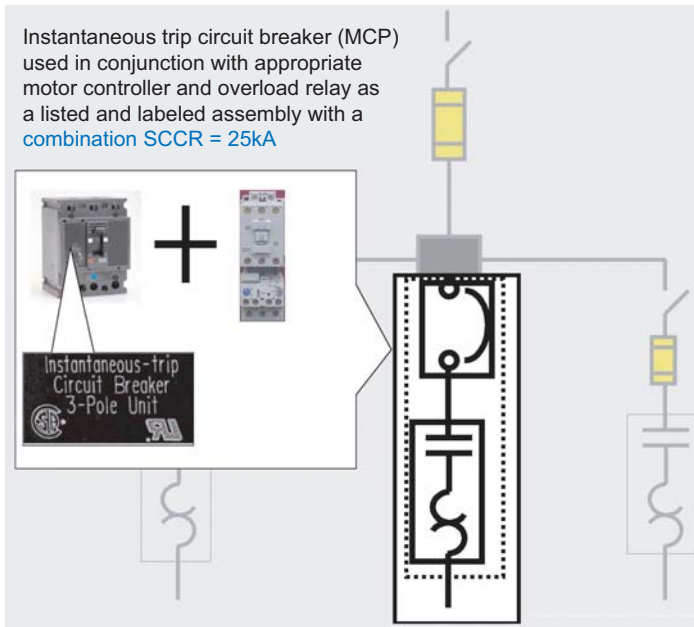

Figure 9.

### Sweep 1 — Step 1 - Branch 3

#### Determine Short-Circuit Current Rating for Branch 3

The components and devices making up Branch Circuit 3 consists of:

- Class CC 30A Fuses providing overcurrent protection
- IEC Contactor and Overload Relay with markings for short-circuit current ratings as shown here

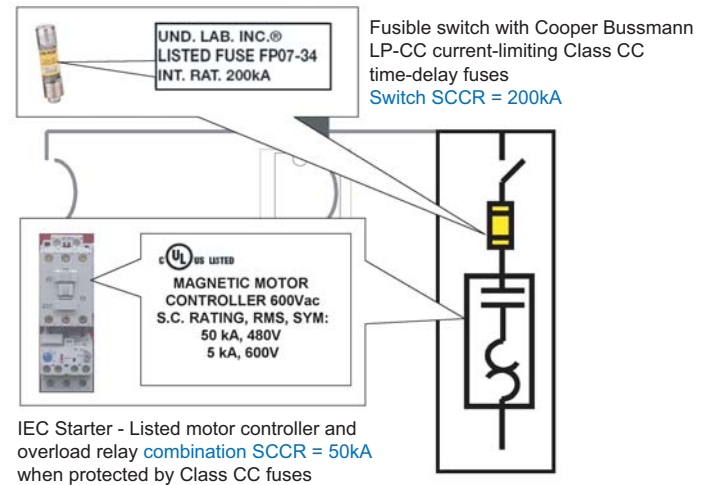

Figure 11.

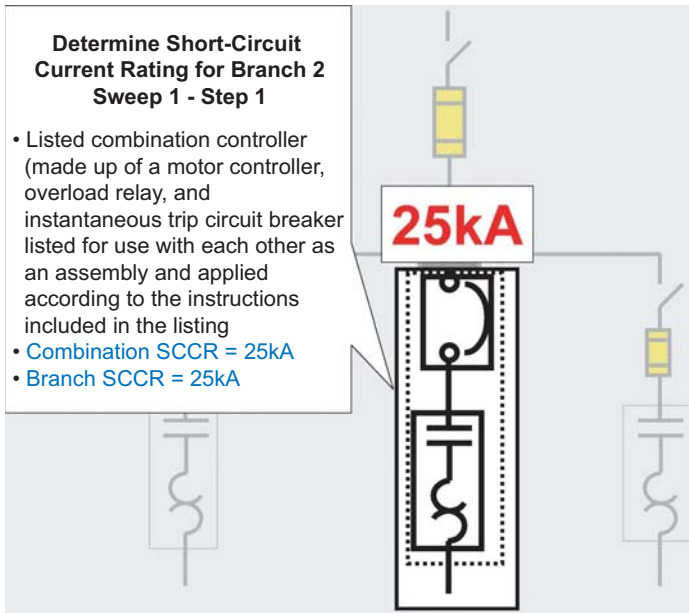

Figure 10.

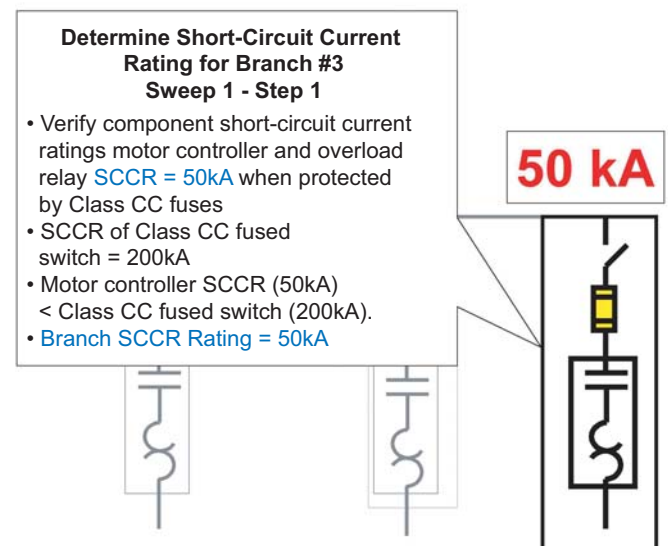

Figure 12. — short-circuit Current Rating for Branch 3 = 50kA

## Determining Assembly SCCR: Example

### Sweep 1 — Step 2 - Feeder 1

#### Determine the Short-Circuit Current Rating for Each Feeder Circuit.

First investigate the feeder circuit components.

A power distribution block is being used in the feeder circuit and the short-circuit current rating is not marked on the device.

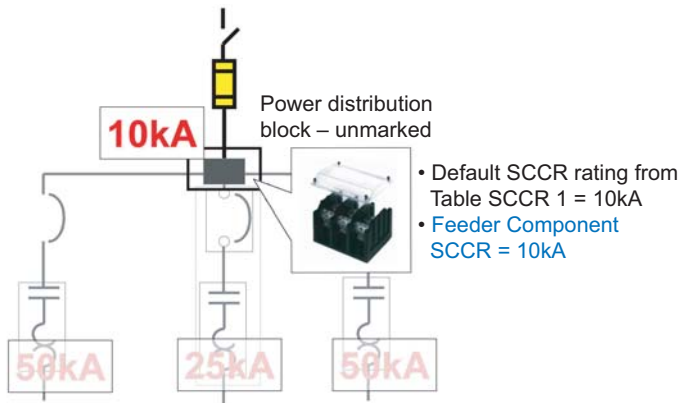

Figure 13.

A Fusible Switch with Cooper Bussmann LPJ current-limiting Class J time-delay fuses is being used in the feeder circuit.

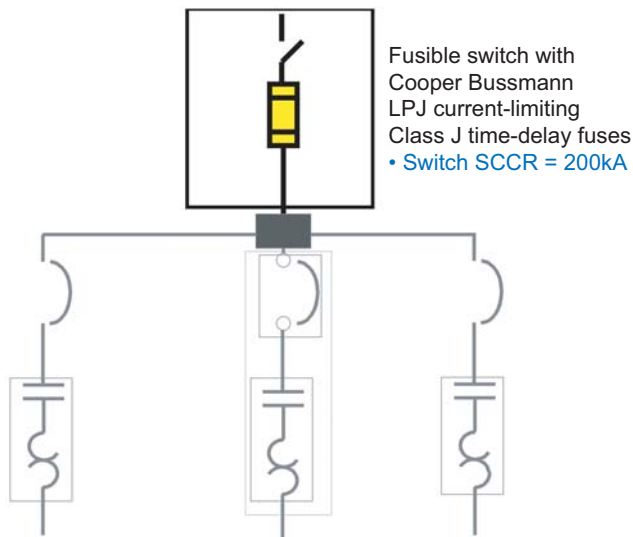

Figure 14.

### Sweep 1 — Step 3 - Feeder 1

#### Modify branch circuit and feeder circuit short-circuit current ratings using current limitation.

From Table SCCR2 the Peak Let-Through Current ( $I_p$ ) for a Class J 60A fuse is:

- 8kA for 50kA available\*
- 10kA for 100kA available\*
- 16kA for 200kA available\*

Lowest SCCR for branches or feeder components = 10kA

$I_p$  Fuse @ 100kA  $\leq$  Lowest SCCR

\* The value used in the short-circuit analysis is based upon the UL umbrella, or maximums, for the type of fuse being used. The actual let-through value of commercially available fuses can be much less than the umbrella value.

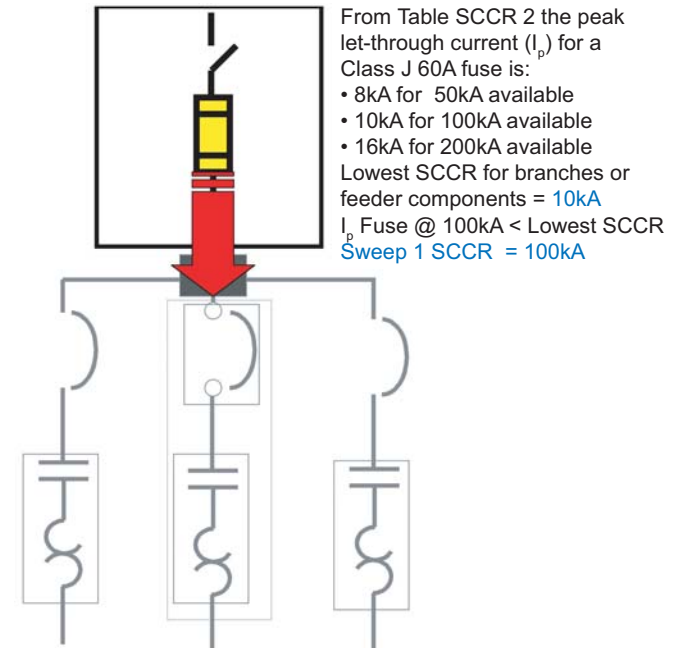

Figure 15 — Assembly short-circuit current rating from Sweep 1 = 100kA.

Since current limitation of the feeder OCPD increased the SCCR of the feeder components from 10kA to 100kA, this analysis will also increase any branch that has a 10kA SCCR or higher to a 100kA SCCR.

**CONTINUE ONTO SWEEP 2 (next page) TO DETERMINE OVERALL RATING**

## Determining Assembly SCCR: Example

### SWEEP 2 —

#### Modifying Assembly Short-Circuit Current Ratings based upon Interrupting Ratings of Overcurrent Protective Devices

Compare the interrupting ratings of all the overcurrent protective devices with the Sweep 1 short-circuit current rating from Sweep 1, Step 4. The lowest rating encountered is the assembly short-circuit current rating.

The interrupting Rating of the MCP in Branch Circuit 2 is the limiting factor for Sweep 2.

Since there is no interrupting rating marked on the MCP or instructions provided with the MCP, use the default value from Table SCCR1, which is 5kA. Therefore the assembly is limited to 5kA since Branch Circuit 2 has an overcurrent protective device with an interrupting rating less than the assembly short-circuit current rating as determined in Sweep 1.

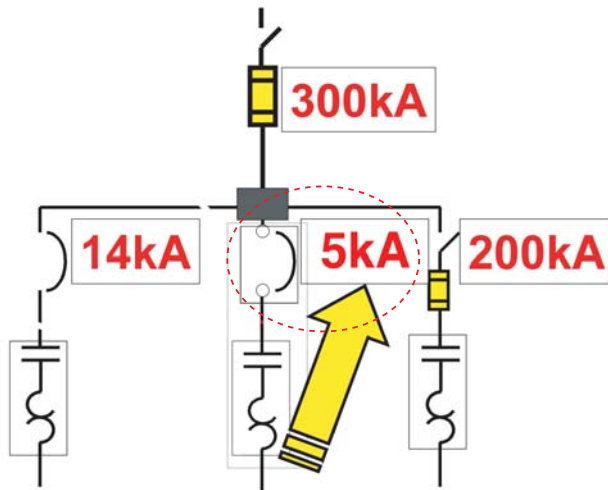

Figure 16. — Limiting rating from Sweep 2 = 5kA

#### 4) Determine the assembly short-circuit current rating

IR Sweep 2 < SCCR from Sweep 1

The low interrupting rating encountered in Sweep 2 actually becomes the rating for the assembly since it represents the device or component with the lowest rating.

	SCCR From Sweep 1 Step 1	SCCR From Sweep 1 Step 2	Adjusted SCCR From Sweep 1 Step 3	SCCR From Sweep 1 Step 4	SCCR Sweep 2	
Branch 1	50kA	-	100kA	100kA	14kA	Assembly SCCR
Branch 2	25kA	-	100kA	100kA	5kA	
Branch 3	50kA	-	100kA	100kA	200kA	
Feeder 1	-	10kA	100kA	100kA	300kA	
			Lowest SCCR From Sweep 1 Step 4 = 100kA	Lowest SCCR From Sweep 2 = 5kA	Lowest SCCR From Sweep 1 Step 4, or Sweep 2 = 5kA	

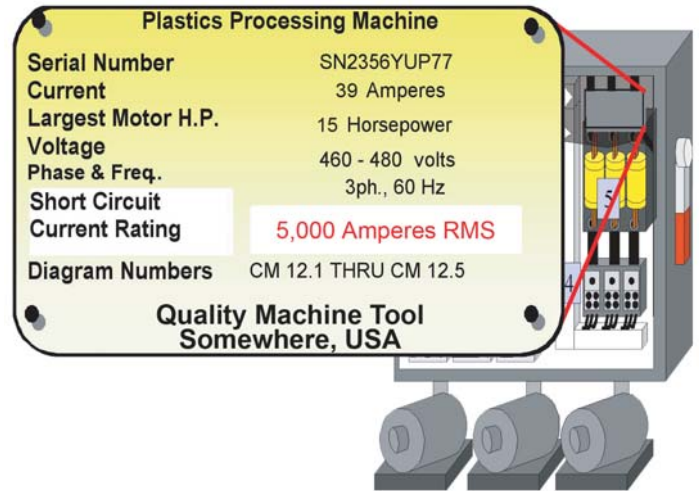

Figure 17. — Overall assembly short-circuit current rating = 5kA

### FIX IT!

#### Further Consideration for This Example

If more than a 5kA short-circuit current rating is desired, a simple fix would be to replace the Instantaneous trip circuit breaker in Branch Circuit 2 with a device with a higher interrupting rating, such as the LP-CC (Class CC) fuses used in Branch Circuit 3 or LPJ (Class J) fuses. The SCCR of this combination motor controller and the entire branch circuit would increase to 100kA and the assembly SCCR would be increased to 14kA.

#### Fix #1 — Replacing MCP With LP-CC Fuses

	SCCR From Sweep 1 Step 1	SCCR From Sweep 1 Step 2	Adjusted SCCR From Sweep 1 Step 3	SCCR From Sweep 1 Step 4	SCCR Sweep 2		
Branch 1	50kA	-	100kA	100kA	14kA	Assembly SCCR	
Branch 2	<del>25kA</del> 100kA	-	100kA	100kA	<del>5kA</del> 200kA		
Branch 3	50kA	-	100kA	100kA	200kA		
Feeder 1	-	10kA	100kA	100kA	300kA		
	<div style="background-color: yellow; width: 20px; height: 10px; display: inline-block;"></div> Fix 1 Changes				Lowest SCCR From Sweep 1 Step 4 = 100kA	Lowest SCCR From Sweep 2 = <del>5kA</del> 14kA	Lowest SCCR From Sweep 1 Step 4, or Sweep 2 = <del>5kA</del> 14kA

## Determining Assembly SCCR: Example

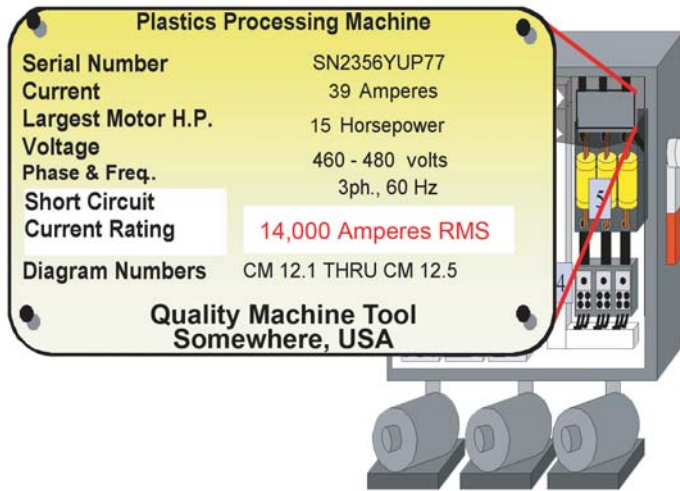

Figure 18. — Overall assembly short-circuit current rating = 14kA

### Another Consideration for This Example

If only the overcurrent protective device in Branch Circuit 2 is replaced, the assembly will still be limited to 14kA of short-circuit current rating as the next lowest rating is in Branch Circuit 1. If the low interrupting rated circuit breaker in Branch Circuit 1 is replaced with the Low-Peak LPJ (Class J) or LP-CC (Class CC) fuses as in Branch Circuit 3, which have a 200kA IR, then the SCCR of this combination motor controller and the entire branch circuit would increase to 100kA and the assembly SCCR would increase to 100kA.

### Find It - Fix It - Forget It Analysis Tool & Solutions

An on line tool is available to make it easy. Go to [www.cooperbussmann.com](http://www.cooperbussmann.com) where you can locate a page for performing short-circuit current rating analysis on industrial control panels. This tool allows you to input your present or planned design and then calculates the assembly short-circuit current rating. Next, the tool identifies the weakest link components that are causing a low assembly short-circuit current rating. Most important suggestions are made on replacement components whereby a higher short-circuit current rating can be achieved.

If the Cooper Bussmann web tools do not offer sufficient information, contact our Application Engineers by phone (636-527-1270) or e-mail ([fusetech@cooperbussmann.com](mailto:fusetech@cooperbussmann.com)).

There are many other considerations in designing, producing, and utilizing industrial control panels to comply with the various codes, standards and best practices. This web site has other resources that assist in understanding the various design considerations such as requirements in the NEC®, NFPA 79, UL 508A and others.

**Fix #2 — Replacing 14kA CB With LP-CC Fuses (Including Fix #1 Replacing MCP)**

	SCCR From Sweep 1 Step 1	SCCR From Sweep 1 Step 2	Adjusted SCCR From Sweep 1 Step 3	SCCR From Sweep 1 Step 4	SCCR Sweep 2	Assembly SCCR
Branch 1	<del>50kA</del> 100kA	-	100kA	100kA	<del>14kA</del> 200kA	
Branch 2	<del>25kA</del> 100kA	-	100kA	100kA	<del>5kA</del> 200kA	
Branch 3	50kA	-	100kA	100kA	200kA	
Feeder 1	-	10kA	100kA	100kA	300kA	
	Fix 2 Changes			Lowest SCCR From Sweep 1 Step 4 = 100kA	Lowest SCCR From Sweep 2 = <del>14kA</del> 200kA	Lowest SCCR From Sweep 1 Step 4, or Sweep 2 = <del>14kA</del> 100kA

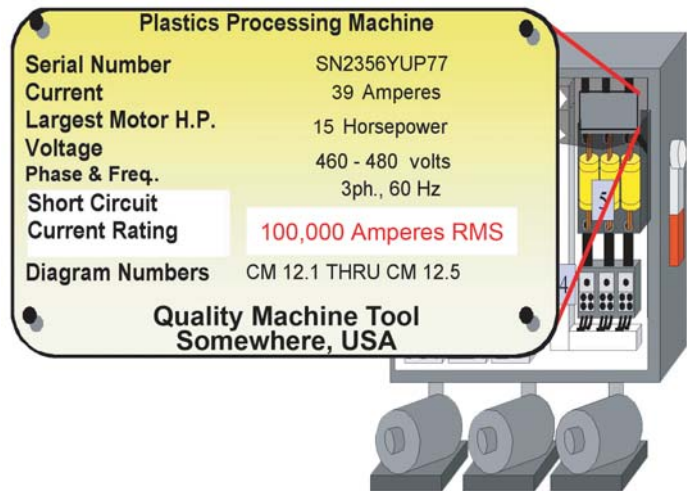

Figure 19. — Overall assembly short-circuit current rating = 100kA