

## Series 15104

### Edge Connectors – 1 Sided Boards / Right Angle Mount

#### SPECIFICATIONS

**Rating:** 10A, 300V

**Center Spacing:** .375" or 3/8" (9.52 mm)

**Wire Range:** #12-22 AWG CU

**Screw Size:** #6-32

**Torque Rating:** 12 in-lb

**Terminals:** Pressure plate terminals with screws set at 45° or 90° angle

**PC Board:** Edge contact accepts standard 1/16" (.0625) PCB

**Contacts:** Tuning fork design of .021" thick phosphorus bronze with .0001" bright tin plating

**Material:** Black, UL Rated 94V0 Thermoplastic

**Operating Temperature:** 95°C max.

**Agency Information:** UL/CSA; CE Certified

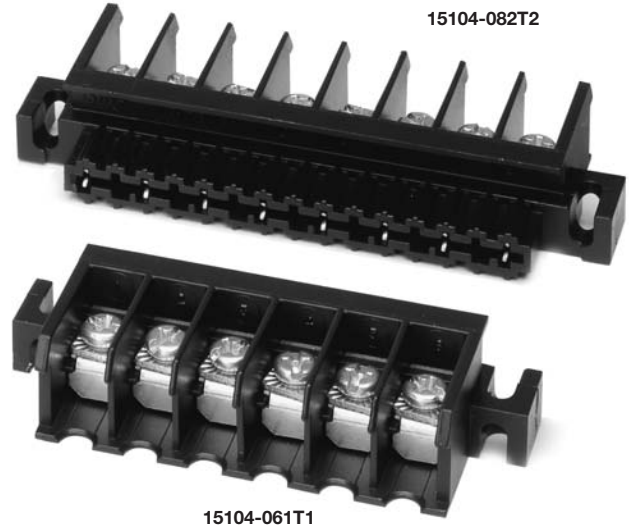

Poles	A	B	C	D	E	Board Width
06	3.00	2.62	2.00	2.16	2.36	1.99
08	3.75	3.37	2.75	2.91	3.11	2.74
10	4.50	4.12	3.50	3.66	3.86	3.49
12	5.25	4.87	4.25	4.41	4.61	4.24
14	6.00	5.62	5.00	5.16	5.36	4.99
16	6.75	6.37	5.75	5.91	6.11	5.74
18	7.50	7.12	6.50	6.66	6.86	6.49
20	8.25	7.87	7.25	7.41	7.61	7.23
22	9.00	8.62	8.00	8.16	8.36	7.98
24	9.75	9.37	8.75	8.91	9.11	8.73
26	10.50	10.12	9.50	9.66	9.86	9.48
28	11.25	10.87	10.25	10.41	10.61	10.23

\* Dimensions in inches. To convert to millimeters, multiply by 25.4.  
Integral standoffs for mounting marker strips - consult factory.

#### 15104 Series

Inches (mm)

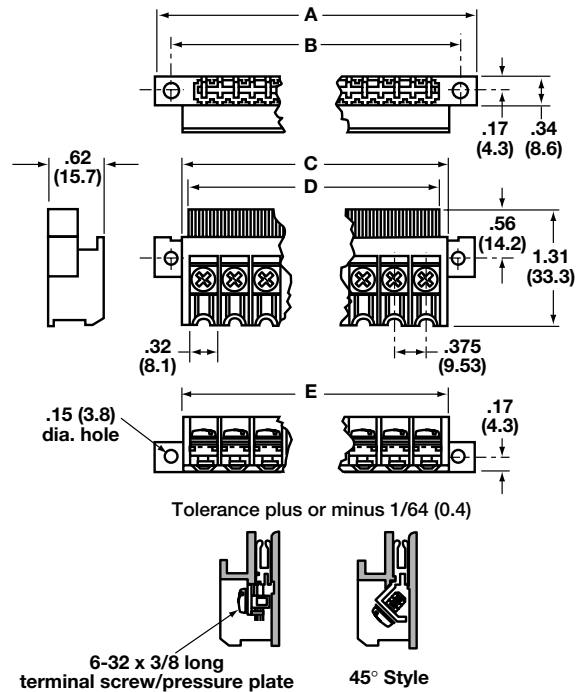

### Part Numbering System

Series

1 5 1 0 4

Poles

□ □

06 to 28 (Increments of 2)

Terminal

□

1 - 90° angle  
2 - 45° angle

Plating

□

T - Tin  
G - Gold\*

Screw

□

1 - #6-32 pan head. w/wire clamp

\* Consult Factory